

LUBRICATION

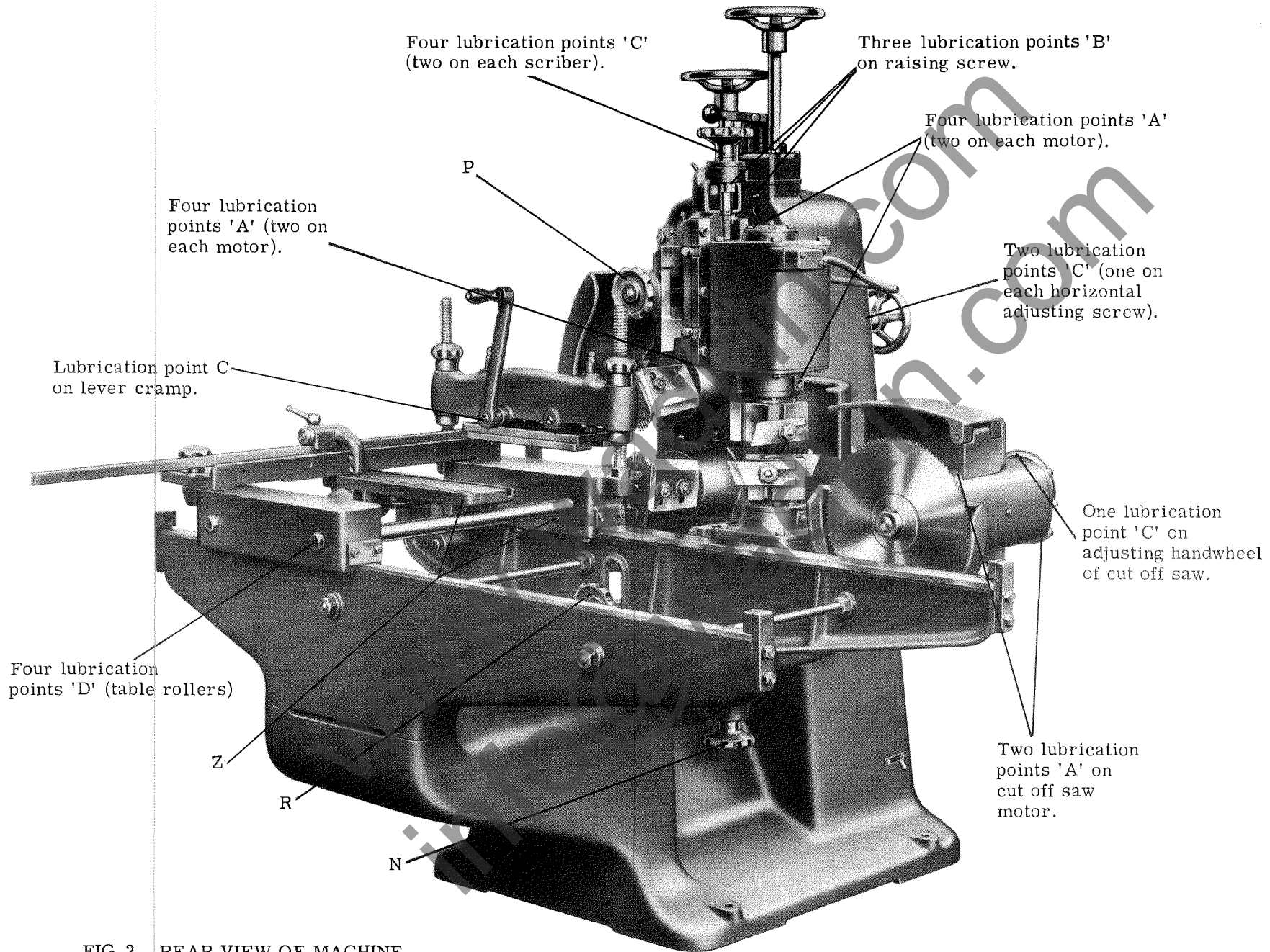

FIG. 2. REAR VIEW OF MACHINE.

Wadkin

SINGLE END TENONER, TYPE E. C. A.

PRINCIPAL DIMENSIONS AND CAPACITIES

	English	Metric
Will admit timber up to	14" x 4½"	356 mm x 114 mm
Will cut tenons at one operation	5" long	114 mm
Fence may be swivelled 45 degrees for angular tenons.		
Distance top cutterhead will rise above the table ...	4¼"	108 mm
Distance taken between shoulders of tenons using turnover stop.	5'0"	1524 mm
Size of table	2'6" x 1'4"	762 mm x 406 mm
Height of table from floor	2'9"	838 mm
Diameter of cutting-off saw	12"	305 mm
Diameter of horizontal and scribing spindles	1¼"	32 mm
Speed of all motors in r.p.m. on 50 cycles	3,000	3,000
Speed of all motors in r.p.m. on 60 cycles	3,600	3,600
Horse power of motors for horizontal cutterheads ...	2	2
Horse power of motors for scribing heads	2	2
Horse power of motor for rear cut-off saw	1	1
Floor space (with stop bar)	7'9" x 5'1"	2362 mm x 1550 mm
Net weight in cwts complete machine with cut-off saw... ..	20½ (2296 lbs)	1042 kilos
Shipping dimensions in cubic feet	112	3.17 cu. metres

DETAILS INCLUDED WITH THE MACHINE

Two motors and control gear	Set of spanners
Two cutterblocks with cutters	Lubricating pump and tin of lubricant.
Two guards	

Wadkin Ltd., Green Lane Works, Leicester. Telephone: Leicester 68151 (7 lines).
 London Office: Brookfield House, 62-64 Brook Street, W. 1. Telephone: Mayfair 7048 and 7049.

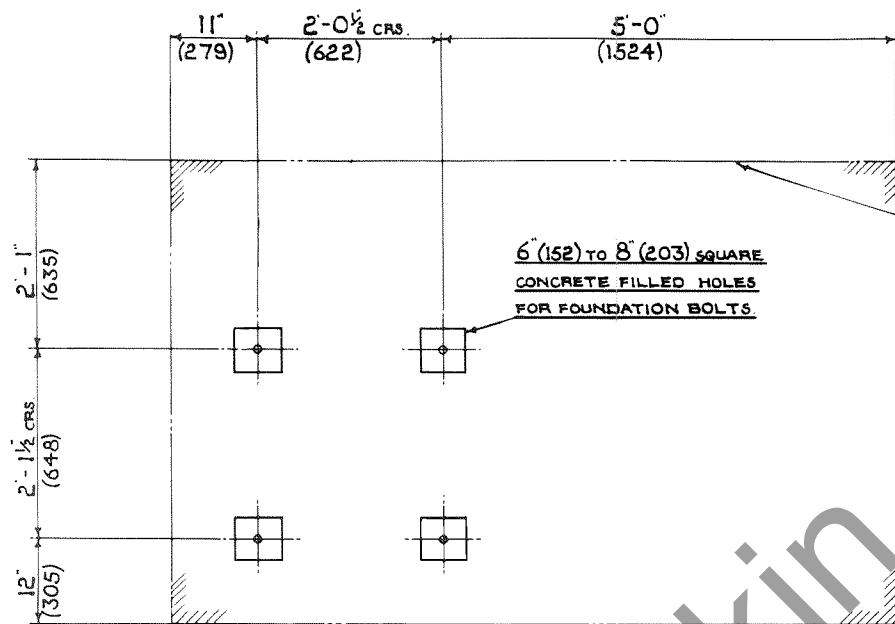
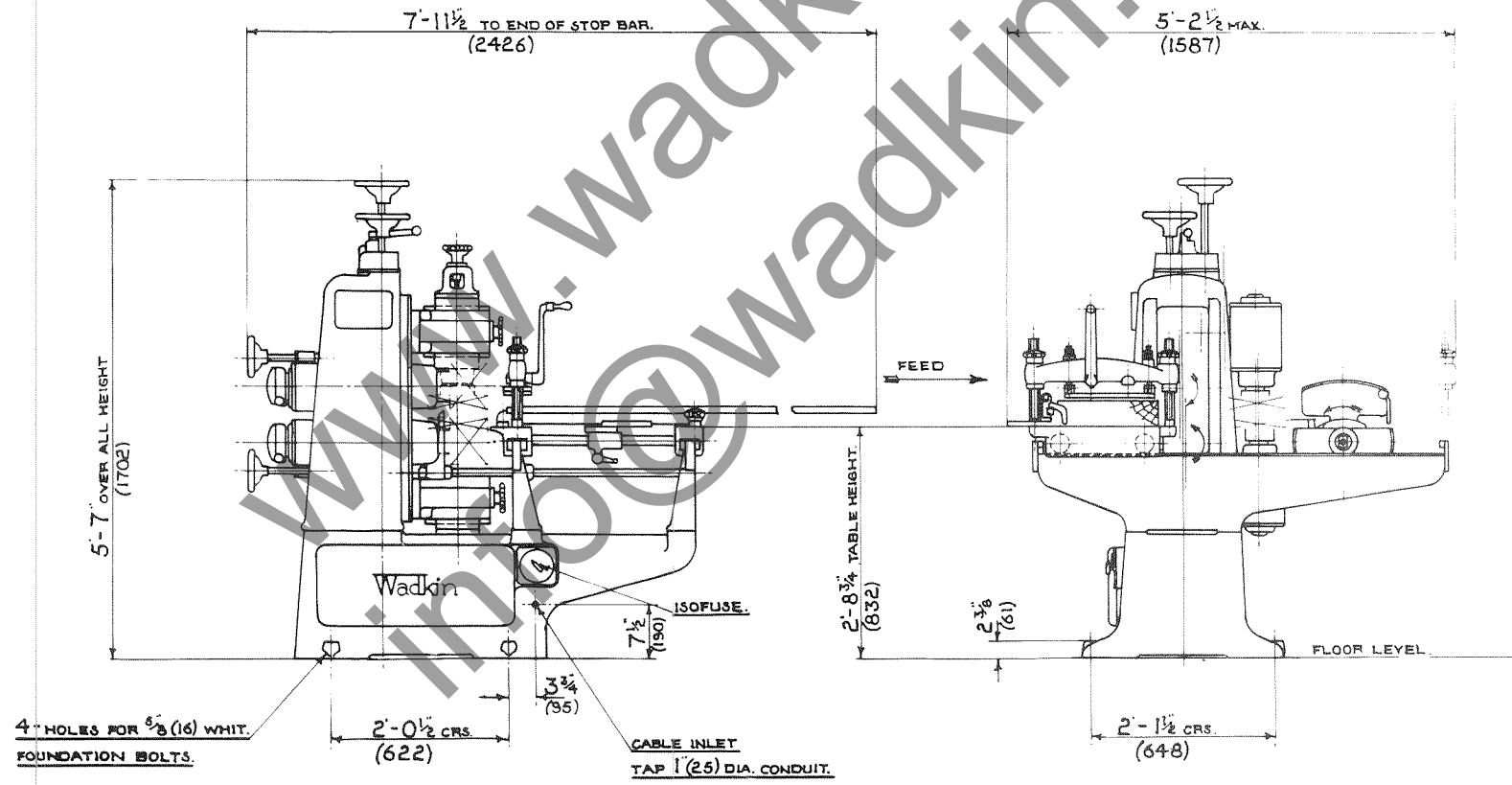

FIG. 1.

FOUNDATION PLAN FOR SINGLE END TENONING MACHINE, TYPE E. C. A. (DIMENSIONS IN INCHES, FEET AND MILLIMETRES).



LUBRICATION. FIG. 2.

Every week thoroughly clean down the machine and renew the thin film of oil on all bright parts not in constant use to prevent rusting.

- A POINTS Every 3 to 6 months give 4 to 6 depressions of the grease gun using Wadkin Ball Bearing Grease Grade L. 6.
- B POINTS Give 1 depression of grease gun weekly using Wadkin Grease Grade L. 6.
- C POINTS Oil twice weekly with Wadkin Machine Oil Grease L. 4.
- D POINTS The table ball bearings are lubricated before despatch. Recharge with Wadkin Grease Grade L. 6 if found necessary in 12 months from installation.

WADKIN RANGE OF OIL AND GREASE LUBRICANTS WITH EQUIVALENTS

Wadkin Grade	EQUIVALENT LUBRICANTS		
	Shell Mex and B. P. Ltd.	Mobil Oil Co. Ltd.	Caltex Lubricants
Machine oil Grade L. 4.	Shell Vitrea Oil 33.	Mobil Vactra Oil (Heavy Medium)	Caltex Aleph Oil.
Ball Bearing Grease Grade L. 6.	Shell Nerita Grease 3.	Mobil Grease B. R. B. 3.	Regal Starfak No. 2 Grease.

HEADSTOCK ADJUSTMENTS.

TOP TENONING HEAD, Fig. 3.

The top tenoning head carriage is moved vertically by rotating handwheel 'A'. This movement is locked by locking handle 'C'. Horizontal adjustment is provided by rotating handwheel 'B' and is locked by locking handle 'D'. The rule 'E' is for setting the tenoning head horizontally. The guard over the cutters moves with the tenoning head and requires no further adjustment.

Note that locking handle 'D' also locks the guard in position.

BOTTOM TENONING HEAD, Fig. 3.

The bottom tenoning head carriage is moved vertically by rotating handwheel 'F', which is locked by locking handle 'H'. Handwheel 'G' is used for horizontal adjustment, and is locked by locking handle 'J'. The tenoning head is set horizontally by rule 'K'. No adjustment need be made to the guard which is fitted to move with the tenoning head.

Note that locking handle 'J' also locks the guard in position.

CUTTERHEAD ADJUSTMENT.

The two heads are set horizontally to give square shouldered tenons by scales and pointers set at 0 (zero) on each scale.

Unequal shouldered tenons as Fig. 5 can be produced by moving over the top head to the desired amount on the scale reading.

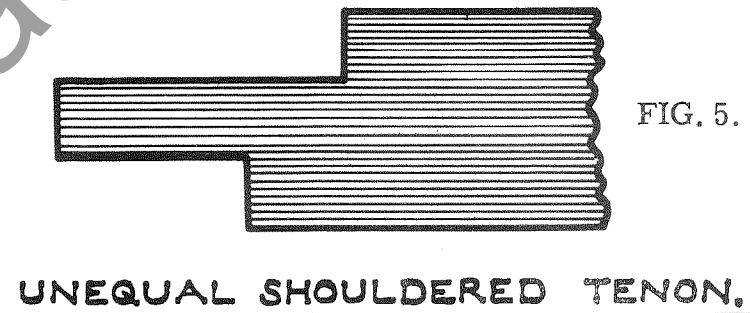
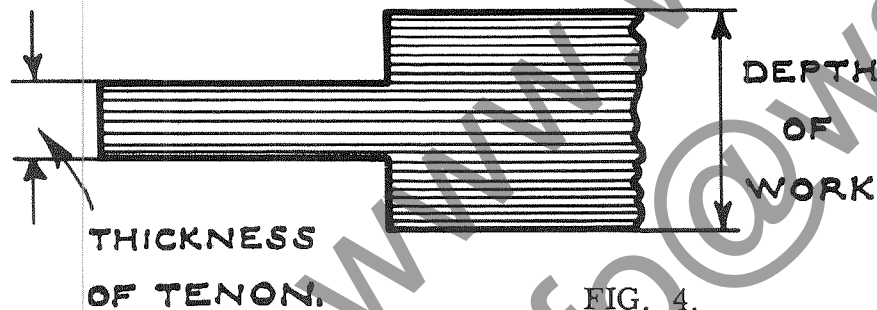

THICKNESS OF TENON.

The heads are adjusted vertically up or down to correspond with the depth of work and the cutter-blocks set to give the desired thickness and position of tenon.

Take care to lock slides after final setting. Hand operated brakes are fitted to each tenon head.

HEADSTOCK ADJUSTMENTS. (Continued)

SCRIBING OR COPE HEAD SPINDLE END.

The scribing cutterblocks are mounted direct on the cutter spindle as shown in Fig. 7, and are driven with the key. They are locked in position with the locknut. The block is recessed to take the nut and a special box spanner is provided with the machine for locking this nut.

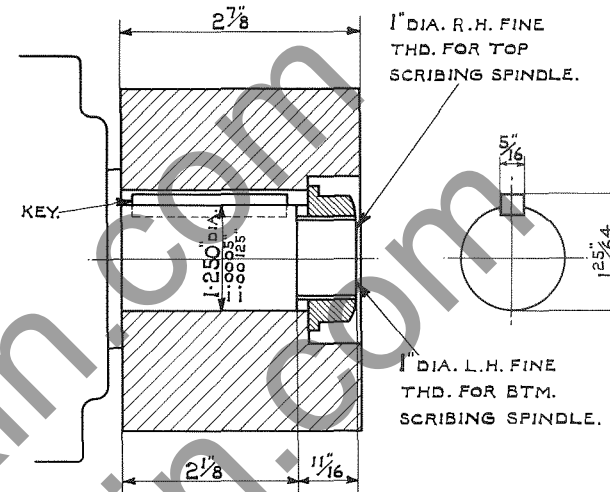

FIG. 7. SCRIBING OR COPE HEAD SPINDLE END.

CUT OFF SAW.

The handwheel 'T', Fig. 3, is used for horizontal adjustment which is locked by locking handle 'U', Fig. 3. No further adjustment need be made to the guards which are fitted to move with the cut-off saw.

The saw is mounted direct on the spindle as shown in Fig. 8. It is driven by the driving pin and supported by 4" diameter saw collars. The locknut secures the saw and collars up against the spindle shoulder.

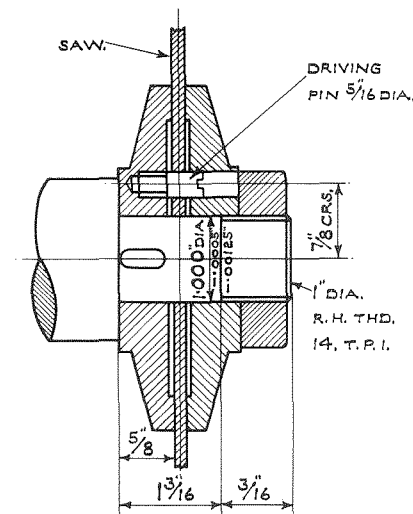

FIG. 8. CUT OFF SAW-SPINDLE END.

ATTACHMENT FOR ADJUSTING TWO TENON HEADS TOGETHER

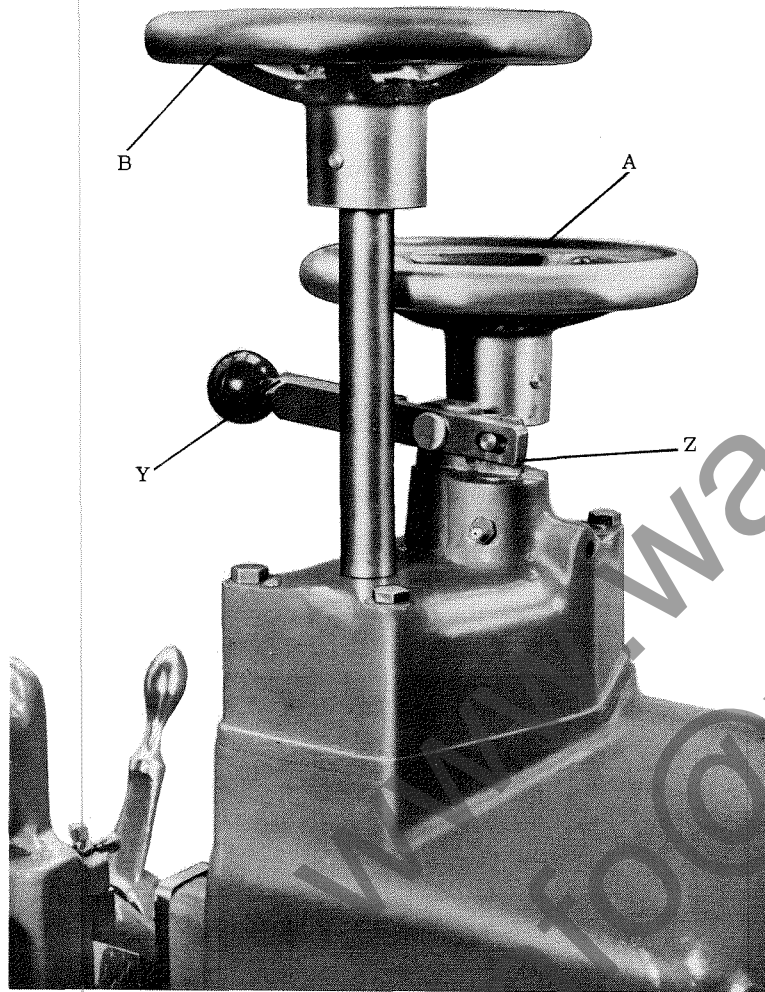

Fig. 9

After the two tenon heads have been set to give the desired thickness of tenon as described on page 7 and the operator wishes to vary its position in the work, the attachment illustrated at Fig. 9 should be brought into use. To do this press lever 'Y' downwards to raise the plunger 'Z' which brings a gear into position joining the gears for independent movement of the heads together. Adjust the combined heads to the required position relative to the table by either handwheel 'A' or handwheel 'B' whichever is more convenient. Before putting the machine to use, take care that the slides are securely locked by the locking handles provided.

METHOD OF DISMANTLING TENON HEAD SPINDLE ASSEMBLY TO FIT NEW BEARINGS.

REAR BEARING

1. Remove end cap EKA 48.
2. Remove locknut No. 2B or 2A.
3. Remove brake drum EC 80.
4. Remove brake housing EKA 47.
5. Remove bearing housing EC 55 or EC 56 and bearing.
6. Knock out bearing and fit replacement SKF 2206 bearing.
7. To reassemble, reverse dismantling operation.

MIDDLE BEARING

8. Repeat operations 1, 2, 3, 4, 5.
9. Remove locknut WA 498 or WA 487 and cutterblock EC 182.
10. Remove plate EH 29.
11. Remove grease retainer EC 79.
12. Remove stator frame EC 57 complete with Stator.
13. Remove end cover EC 11.
14. Remove locknut EC 132 or EC 133.
15. Withdraw shaft EC 49 or EC 50 from rear end.
16. Remove rotor from shaft.
17. Loosen countersunk screw and remove locknut No. 7A and 7B.
18. Remove grease retainer EH 65.
19. Remove bearing and fit replacement SKF 2209 bearing.
20. To reassemble, reverse dismantling operations.

FRONT BEARING

21. Repeat operations 1, 2, 3, 4, 5, 9, 10, 11, 12, 13, 14, 15.
22. Knock out bearing from EH 18/A or EH 17/A and fit replacement SKF 2208 bearing.
23. To reassemble, reverse dismantling operations.

TO REMOVE STATOR FROM FRAME

Remove $\frac{1}{4}$ " B. S. P. Pipscrew 'M' from frame and knock out stator.

IMPORTANT

When replacing stator, care must be taken to avoid drilling into the windings. Maximum depth of pip-screw hole is $\frac{5}{16}$ " to the tip of the drill.

BOTTOM TENON SPINDLE E. C. 50

Thread 'N' 1" fine thread 14 T. P. I. R. H.
 Thread 'P' $1\frac{1}{2}$ " fine thread 14 T. P. I. R. H.
 Thread 'Q' $1\frac{3}{4}$ " fine thread 14 T. P. I. L. H.
 Thread 'R' $1\frac{1}{8}$ " fine thread 14 T. P. I. L. H.

TOP TENON SPINDLE E. C. 49

Thread 'N' 1" fine thread 14 T. P. I. L. H.
 Thread 'P' $1\frac{1}{2}$ " fine thread 14 T. P. I. L. H.
 Thread 'Q' $1\frac{3}{4}$ " fine thread 14 T. P. I. R. H.
 Thread 'R' $1\frac{1}{8}$ " fine thread 14 T. P. I. R. H.

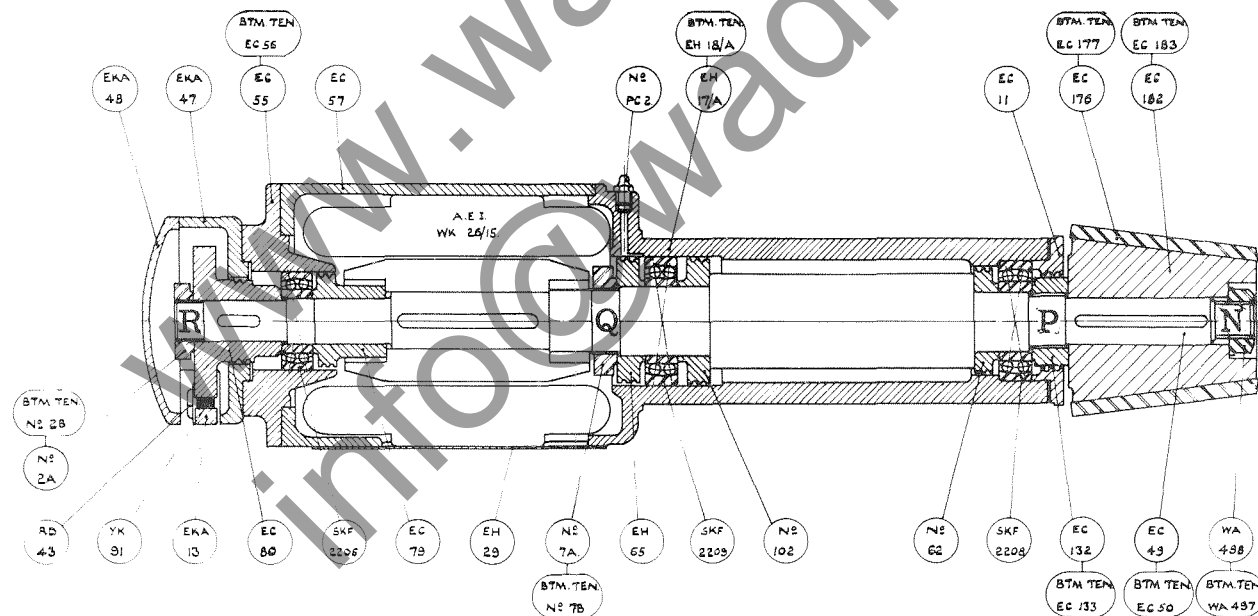

VERTICAL CROSS SECTION THRO' TOP TENON SPINDLE UNIT.

CUT-OFF SAW SPINDLE ASSEMBLY.

METHOD OF DISMANTLING TO FIT NEW BEARINGS, REAR BEARING.

1. Remove cap 'A', Fig.12
2. Loosen countersunk screw and remove locknut 'B'.
3. Remove bearing housing 'C'.
4. Knock out bearing from housing and fit replacement.
5. To reassemble reverse dismantling operation.

FRONT BEARING.

6. Remove locknut 'D', collar 'E', saw and collar 'F'.
7. Remove end cap 'G'.
8. Repeat operations 1, 2 and 3.
9. Withdraw spindle from saw end of frame 'H'.
10. Knock out taper pin and remove collar 'J'.
11. Remove rotor from shaft.
12. Loosen countersunk screw and remove locknut 'K'.
13. Remove grease retainer 'L'.
14. Remove bearing from shaft and fit replacement.
15. To reassemble reverse dismantling operation.

TO REMOVE STATOR FROM FRAME.

Remove $\frac{1}{4}$ " B. S. P. Pipscrew 'M' from frame and knock out stator.

IMPORTANT.

When replacing stator care must be taken to avoid drilling into the windings. Maximum depth of pipscrew hole is $\frac{5}{16}$ " to the tip of the drill.

CUT OFF SAW SPINDLE E. H. 92.

Thread 'N' 1" fine thread 14 T. P. I. R. H.
Thread 'P' $1\frac{1}{2}$ " fine thread 14 T. P. I. L. H.
Thread 'Q' 1" fine thread 14 T. P. I. L. H.

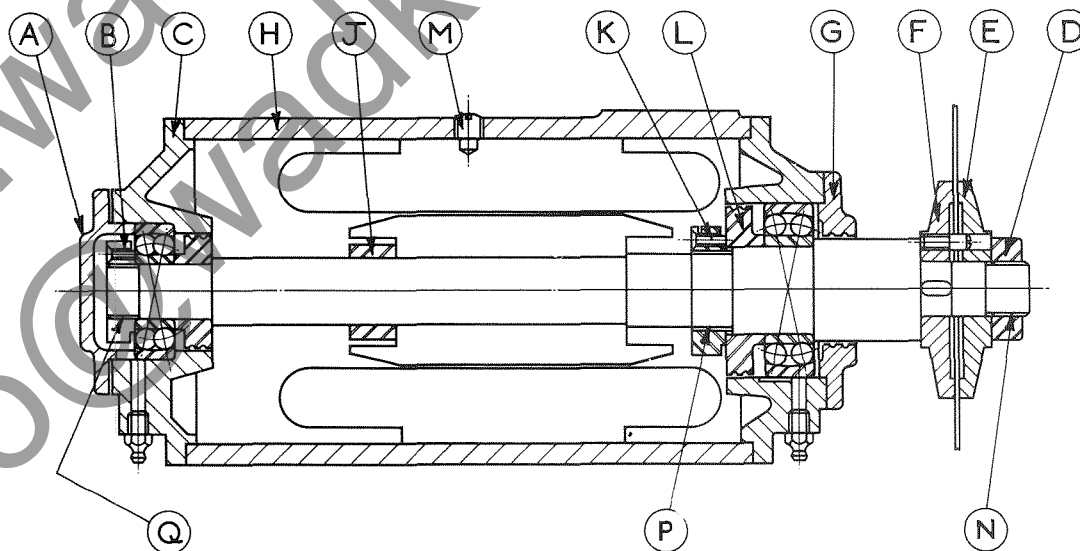

CUT - OFF SAW SPINDLE ASSEMBLY. FIG. 12.

CUTTER EQUIPMENT

MOULDING ON TOP TENON SPINDLE.

By fitting a $4\frac{1}{16}$ " square x $2\frac{7}{8}$ " long cutter-block EM244 shown in section in Fig. 13 on the top tenon head a wide range of moulding can be carried out. A making up collar and four $\frac{5}{8}$ " dovetail bolts complete with nut and washer are supplied. Cutters as used on scribing heads are suitable for use on these cutterblocks.

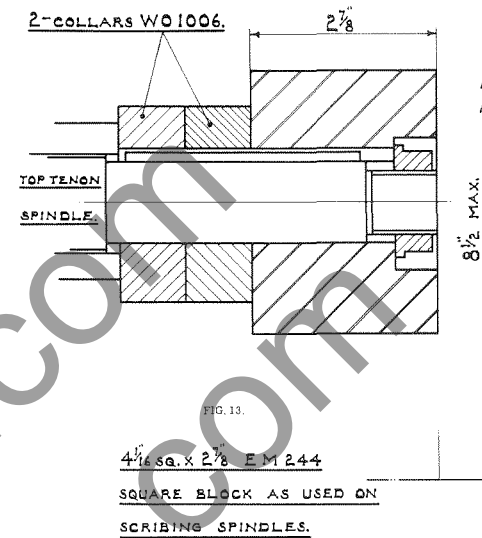

FIG. 13.

$4\frac{1}{16}$ SQ. X $2\frac{7}{8}$ EM 244
SQUARE BLOCK AS USED ON
SCRIBING SPINDLES.

EXPANDING TRENCHING AND GROOVING HEADS.

The type of heads supplied are shown in section in Fig. 14 fitted on the top tenon spindle and are supplied complete with spacing washers and two outside collars. The heads are provided with side or spur cutters to give clean shoulders in the grooves. They can be quickly adjusted to cut any width of groove within their range by means of the set of spacing washers. Two sizes of head are made to cut grooves as follows :-

$8\frac{1}{2}$ " diameter cutting circle

Head J. P. 541 for grooves $\frac{3}{8}$ " to $1\frac{1}{16}$ " wide
up to $\frac{9}{16}$ " deep.

Head J. P. 543 for grooves $1\frac{1}{16}$ " to $1\frac{1}{4}$ " wide
up to 1" deep.

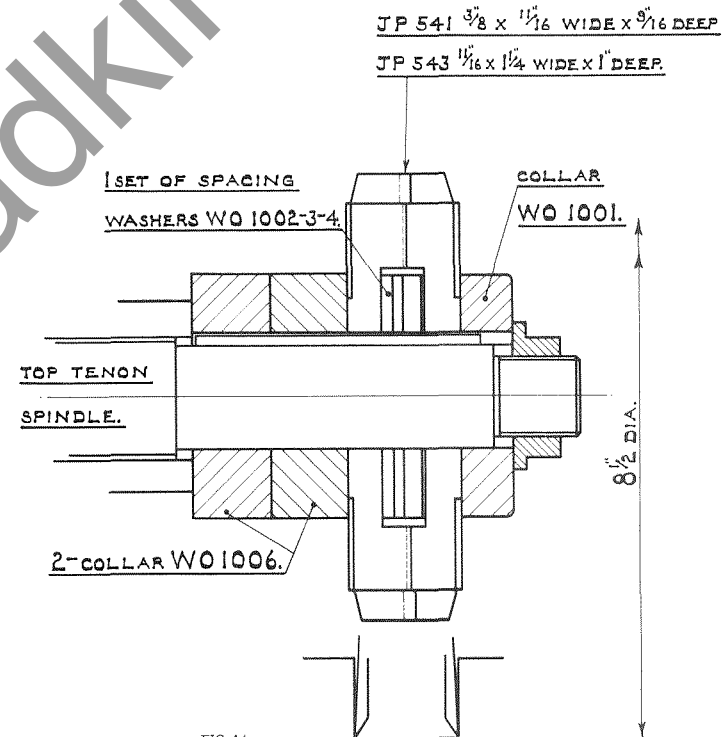

FIG. 14.

EXPANDING TRENCHING HEAD.

CUTTER EQUIPMENT

DADO HEADS

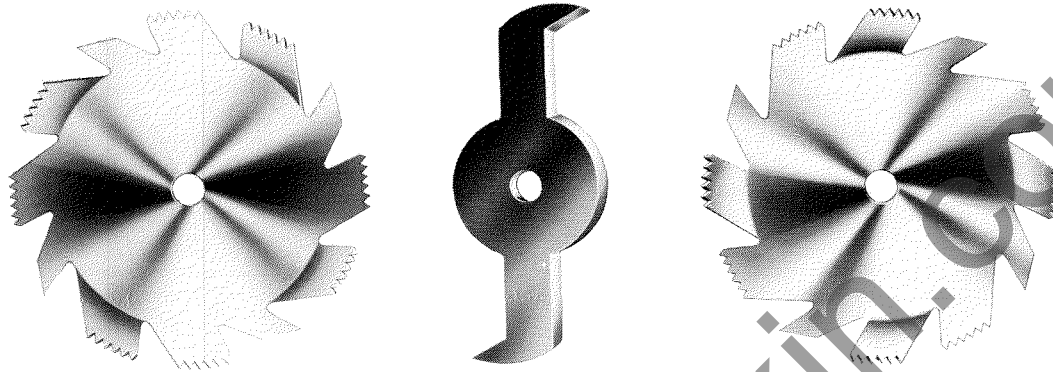

FIG. 18

Outside Cutter.

Inside Cutter.

Outside Cutter.

The Dado head is made up in sets and each set consists of two outside cutters, $\frac{1}{8}$ " thick, and several inside cutters of various thicknesses as illustrated in Fig. 18. A dado head mounted on the top tenon spindle is shown in Fig. 19. Sets are available for cutting grooves up to a maximum of 2" wide. Depending on the type of work to be undertaken cutters up to a maximum of 8" diameter can be used. The dado head gives a smooth finish, but each cutter has to be placed on the spindle separately and the making up collar and outside cutter taken off and replaced when adjustments are necessary. For quick set up and easy maintenance the expanding trenching head illustrated in Fig. 14 is recommended.

SPECIAL CUT OFF SAW.

If desired a flat cross cut saw fitted on the top tenon spindle can be used in lieu of a cut off saw. A saw sleeve is fitted on the spindle and a locknut used to secure the sleeve to the spindle. When this type of saw is required please state details of the maximum and minimum lengths of tenons and thickness of timber to be worked so that the correct diameter of saw can be recommended.

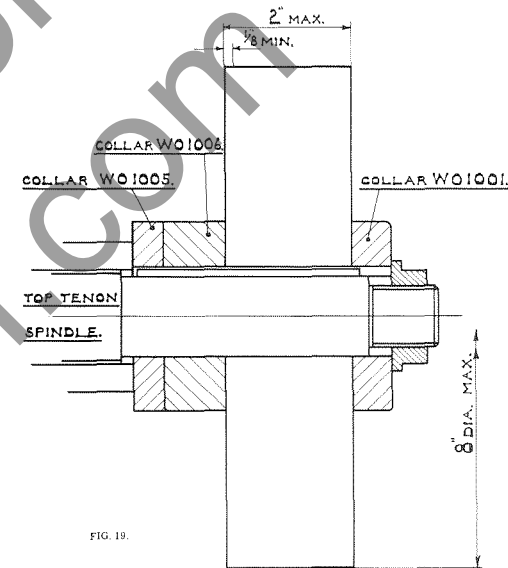

DADO HEADS AND SET OF SPACING COLLARS.

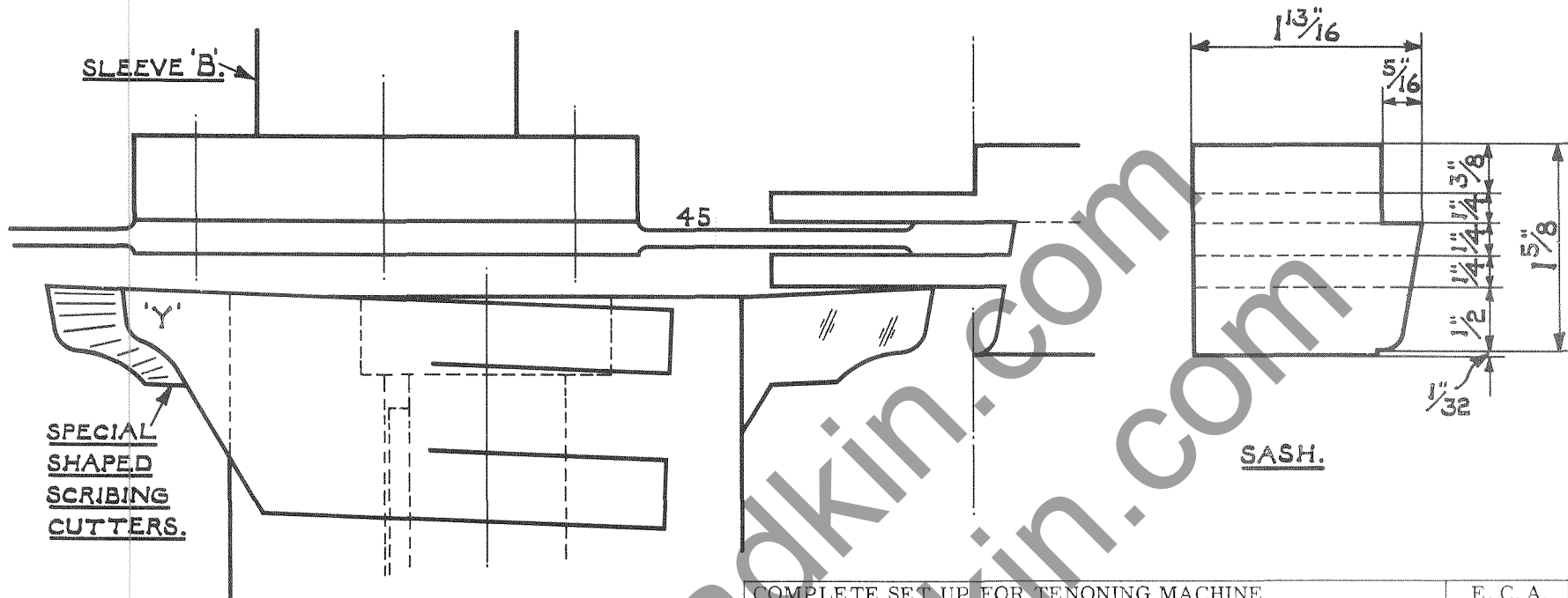

COMPLETE SET UP FOR TENONING MACHINE		E. C. A.
Sleeves		'B' 2-off
Saws Nos. 43, 44, 45 and 46 (as drawing)		1-off each
Special high speed steel on iron scribing cutters 'X' (as drawing)		4-off
Special high speed steel on iron scribing cutters 'Y' (as drawing)		4-off

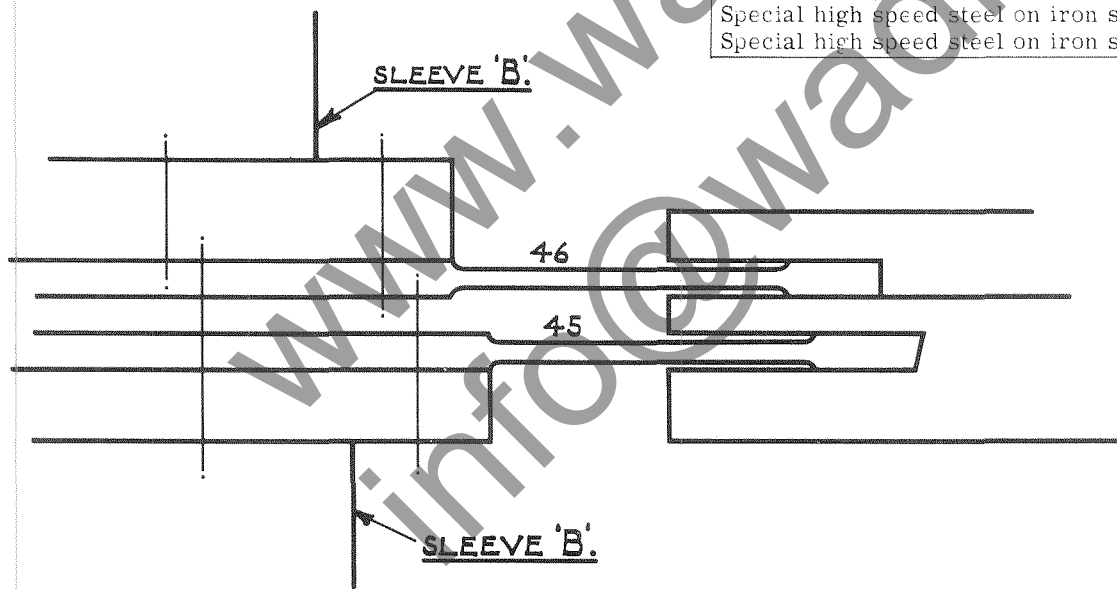

TENON BLOCK ADZE CUTTER GRINDING ATTACHMENT
USED ON UNIVERSAL CUTTER GRINDER, TYPE N. H.

This attachment provides an accurate method of grinding and maintaining the correct shape of the adze cutters by mechanical methods. It consists of a fixed finger working along the edge of the cutter, the cutterblock assembly being mounted on the swivelling table. The standard arbor supplied with the attachment will accommodate any Wadkin tenon block.

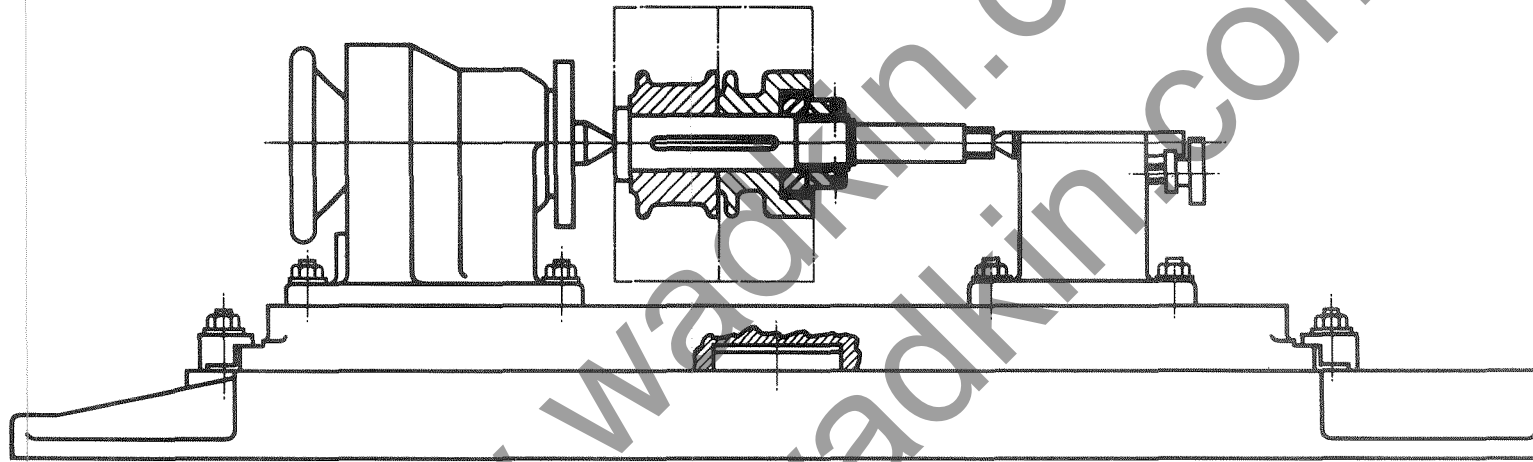

FIG. 24

Fig. 24 shows the mounting of the block. Blocks from machines E. C. A. are mounted on the $1\frac{1}{4}$ " diameter portion of the arbor. The swivelling table is mounted on the machine table, dividing head and tailstock then being placed in position. A No. 4 Morse taper dead centre is now fitted into the bore of the dividing head, the arbor complete with block being mounted between the two centres in the head and tailstock giving the complete table assembly as shown in Fig. 24. The dividing head will not be used for indexing purposes so this can be locked. The screws holding the spur cutters in the tenon blocks should be loosened and the spur cutters dropped below the cutting circle diameter. This is to prevent the spur cutters fouling the grinding wheel during the grinding operation.

TENON BLOCK ADZE CUTTER GRINDING ATTACHMENT (Continued)

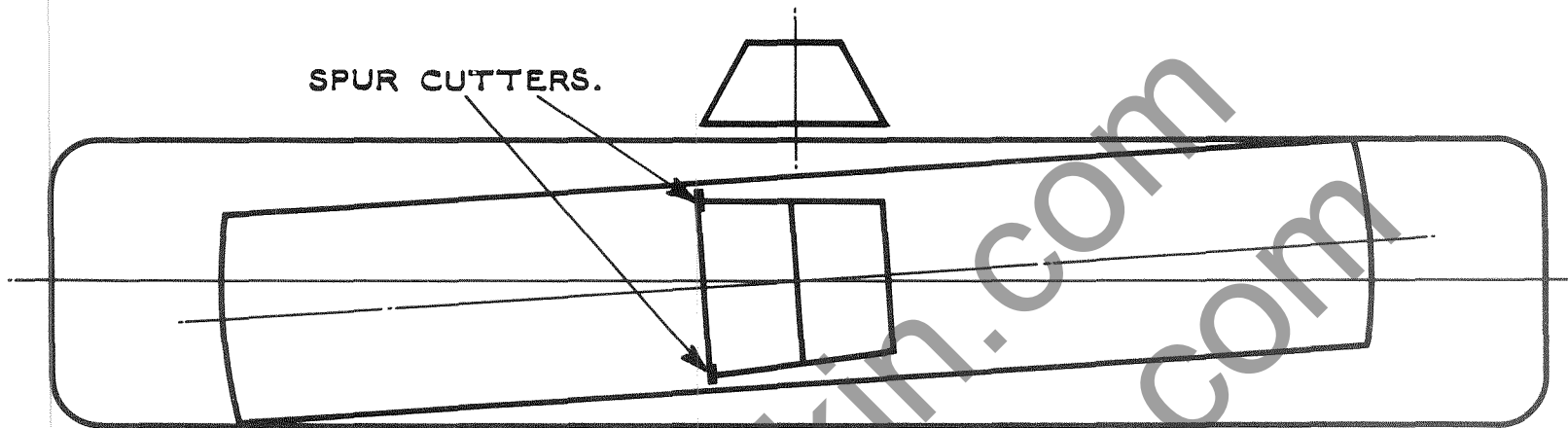

Fig. 27

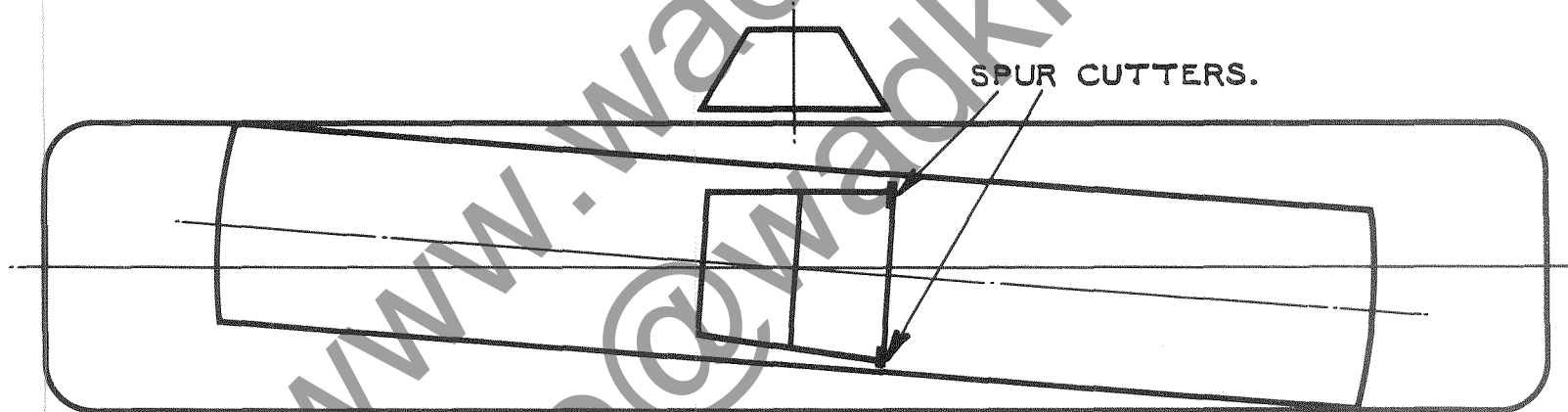

FIG. 28

The edge of the first knife should now be set between the finger and the wheel, and by means of the rise and fall and cross traverse to table, the knife should be brought into a position to give the correct grinding angle. The knives are now ready to be ground. Keeping the left hand on the tenon block and pressing the knife lightly back on to the finger, the right hand is used to traverse the table longitudinally, as shown in Fig. 30.

FREE HAND METHOD OF GRINDING TENON CUTTERS TO GAUGE.

The template supplied with the machine is used when free hand grinding tenon cutters to gauge. It is necessary to ensure that the cutting edge of the cutter is shaped correct to the template otherwise the tenons will not be flat or parallel.

The correct cutter angle of 30° should be maintained. This is to give the correct strength to the cutting edge and clearance on the cutting track.

Hollow grinding is recommended wherever possible, as a perfect cutting edge is more easily obtained by stoning. When stoning a flat ground cutter a good edge is more difficult to obtain due to the tendency to rock the stone and leave a convex face. When hollow grinding is carried out the angle of the cutting edge should be kept as near 30° as possible.

SETTING UP STAND T. S. S. FOR TENONING HEADS. FIG. 31.

Setting up the curved adze cutters on horizontal tenoning heads can be considerably simplified and speeded up by the use of this stand.

On the stand are engraved a series of curves representing the cutting track of cutters used on various machines. The wood block is first adjusted so that it is in line with the appropriate curve.

Fit the head on the arbor up against the locking collar as shown in Fig. 31. Rotate the cutterblock to check that as the edge of the cutter passes the centre of the wood it just touches all along. The cutter will need adjustment either if it will not pass the wood or if there is a gap between the cutter and the wood.

The head is slightly tapered to obtain undercutting of the shoulder as described below.

CUT OF THE HEADS.

The cut of the heads is shown in Fig. 32. The undercutting of the shoulder, which is exaggerated, is necessary to ensure clean fitting shoulders when cramped together.

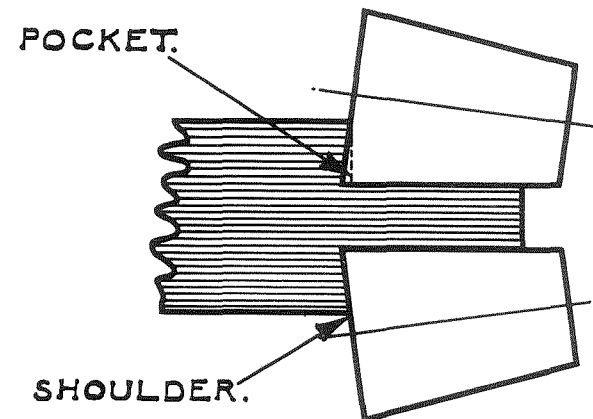
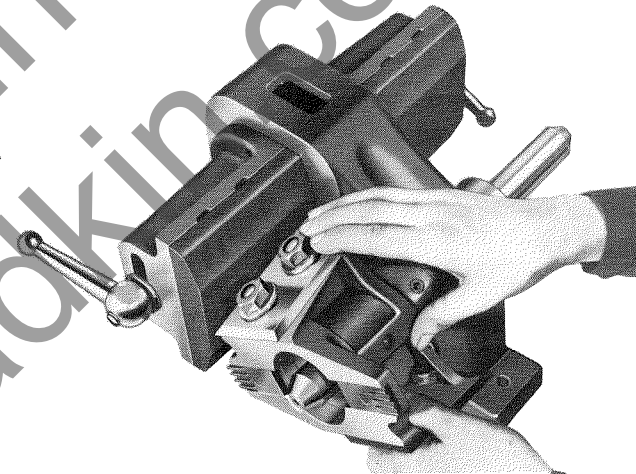

Fig. 32

CUTTER GRINDING

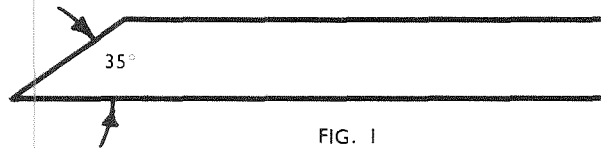

FIG. 1

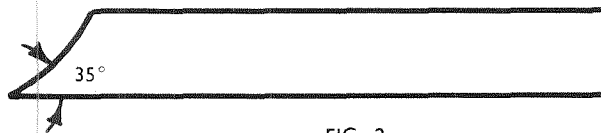

FIG. 2

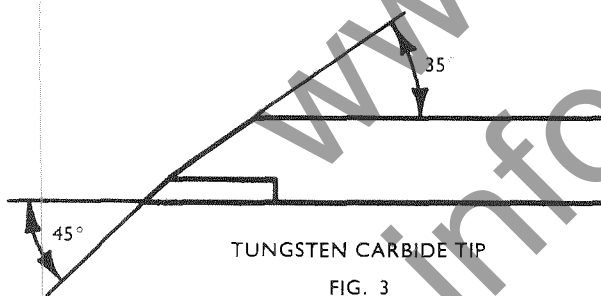

FIG. 3

Cutters should be ground carefully avoiding any overheating as this will crack or soften cutters so that they will not stand up to the work. A solution of soluble oil and water should be handy and the cutters should be held in this occasionally to cool them. This solution will also prevent rusting. Cutters should never be allowed to become discoloured during grinding, as this indicates overheating.

The correct cutter angle of 35° for most cutters should be maintained, this is to give the correct strength to the cutting edge. When hollow grinding is carried out, the angle of the cutting edge should be kept as near 35° as possible, see Figs. 1 and 2.

Hollow grinding is recommended wherever possible, as a perfect cutting edge is more easily obtained by stoning. When stoning a flat ground cutter a good edge is more difficult to obtain due to the tendency to rock the stone and leave a convex face.

Good open grain wheels should be used and not allowed to become glazed, as this will cause excessive heat.

About 12" diameter for new wheels gives the best radius for the hollow grind and the economic life. 8" wheels used down to 6" leave the grind too hollow.

Tungsten carbide tipped cutters should be purchased to the shape required and only need re-grinding. In this case cutters should be relieved at 35° on steel and the tips finished with a diamond impregnated wheel at 45° as shown, using only very light cuts to prevent cracking.

The diamond wheel should not be allowed to touch the steel backing as this clogs the wheel and causes excessive heat. Where available a copious flow of coolant should be used. They may be honed with a diamond hand lap, as the cutter becomes dull, until a re-grind is necessary.

A thin oil lubricant should be used on the hand lap.

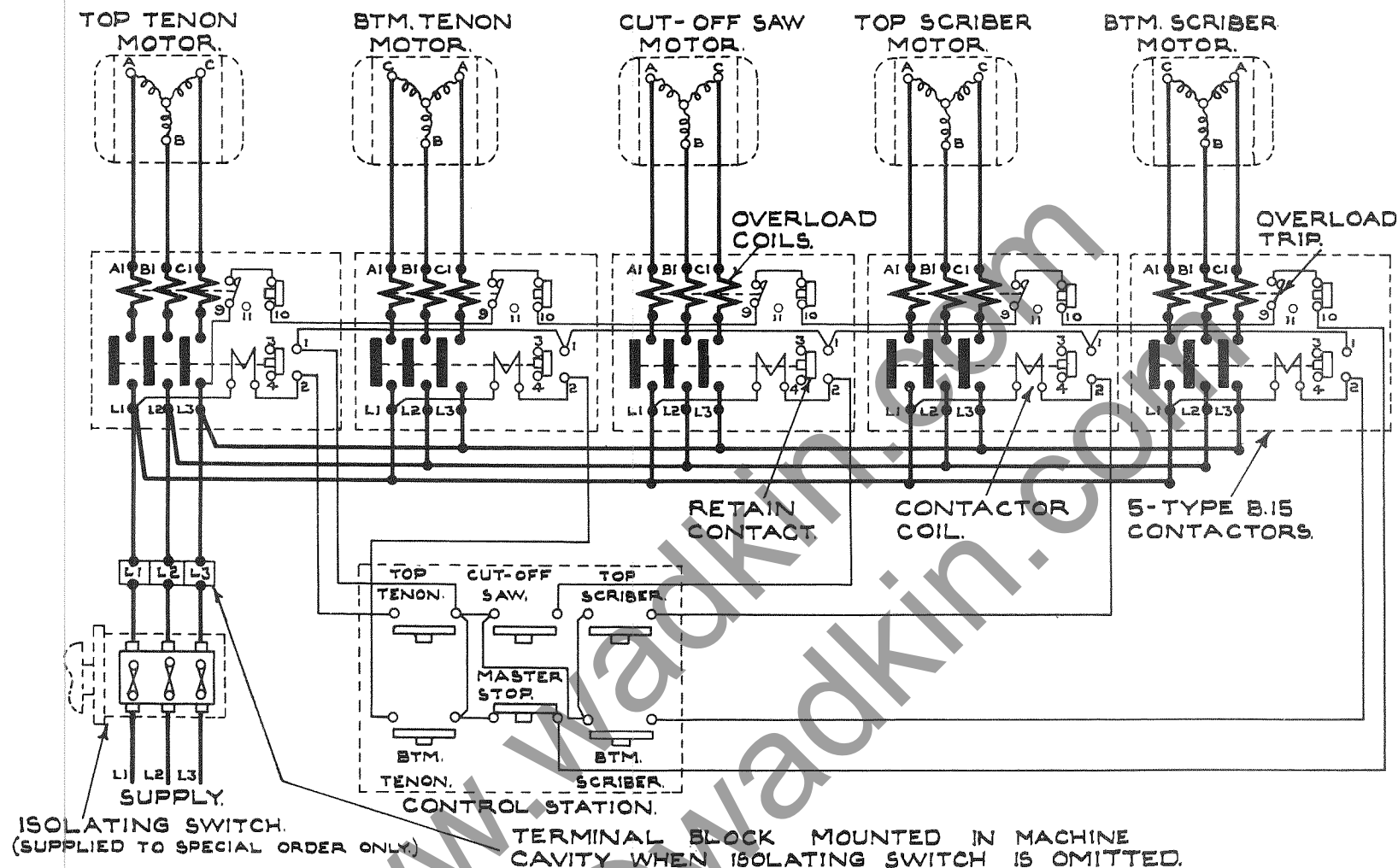

INSTALLATION INSTRUCTIONS.

FIT TRIPLE POLE ISOLATING SWITCH NEAR MACHINE UNLESS SUPPLIED BY WADKIN LTD. TO SPECIAL ORDER, SO THAT THE ELECTRICAL GEAR MAY READILY BE ISOLATED FOR INSPECTION PURPOSES. BRING SUPPLY CABLES TO ISOLATING SWITCH AND TO L1, L2, L3 AT CONTACTOR PANEL THROUGH CONDUIT WHICH SHOULD BE SCREWED INTO THE MACHINE AND SECURED BY MEANS OF LOCKNUTS. A HOLE IS PROVIDED IN THE MACHINE FRAME FOR THE CONDUIT CARRYING THE SUPPLY CABLES TO THE CONTACTORS. ENSURE THAT THE DIRECTION OF ROTATION IS CORRECT BEFORE PUTTING THE MACHINE INTO SERVICE, TO REVERSE ROTATION INTERCHANGE INCOMING SUPPLY CABLES L1 AND L3 AT ISOLATING SWITCH.

OPERATING INSTRUCTIONS.

TO START MACHINE: CLOSE ISOLATING SWITCH AND PRESS THE 'START' BUTTONS FOR HEADS WHICH ARE REQUIRED TO OPERATE. TO STOP MACHINE: PRESS 'STOP' BUTTON. TO LOCK OFF MACHINE: PRESS AND TURN 'STOP' BUTTON, THIS MUST BE RELEASED BEFORE A START CAN BE MADE.

OVERLOAD.

SHOULD THE MACHINE STOP DUE TO OVERLOAD WAIT FOR A SHORT TIME TO ALLOW THE HEATER COILS TO COOL, THEN START IN THE USUAL MANNER.



... blow away harmful dust, chips and dirt with a Wadkin Electric Blower

No motor can run at its maximum efficiency with its ventilating duct or control gear covered with dust and dirt. Sooner or later the resultant overheating will cause serious trouble.

Similarly, accumulations of chips and dust, in the mechanical parts of the machine can interfere with its efficiency. A few minutes a week for blowing down all Woodworking Machinery will be amply repaid in better and easier running, in increased life, and freedom from breakdown.

Blowers can be supplied for single phase A.C. or Direct Current for any voltage up to 250.

Please state voltage when ordering.



TYPE R.A. SIZE, N°1 MAGNETIC STARTERS.

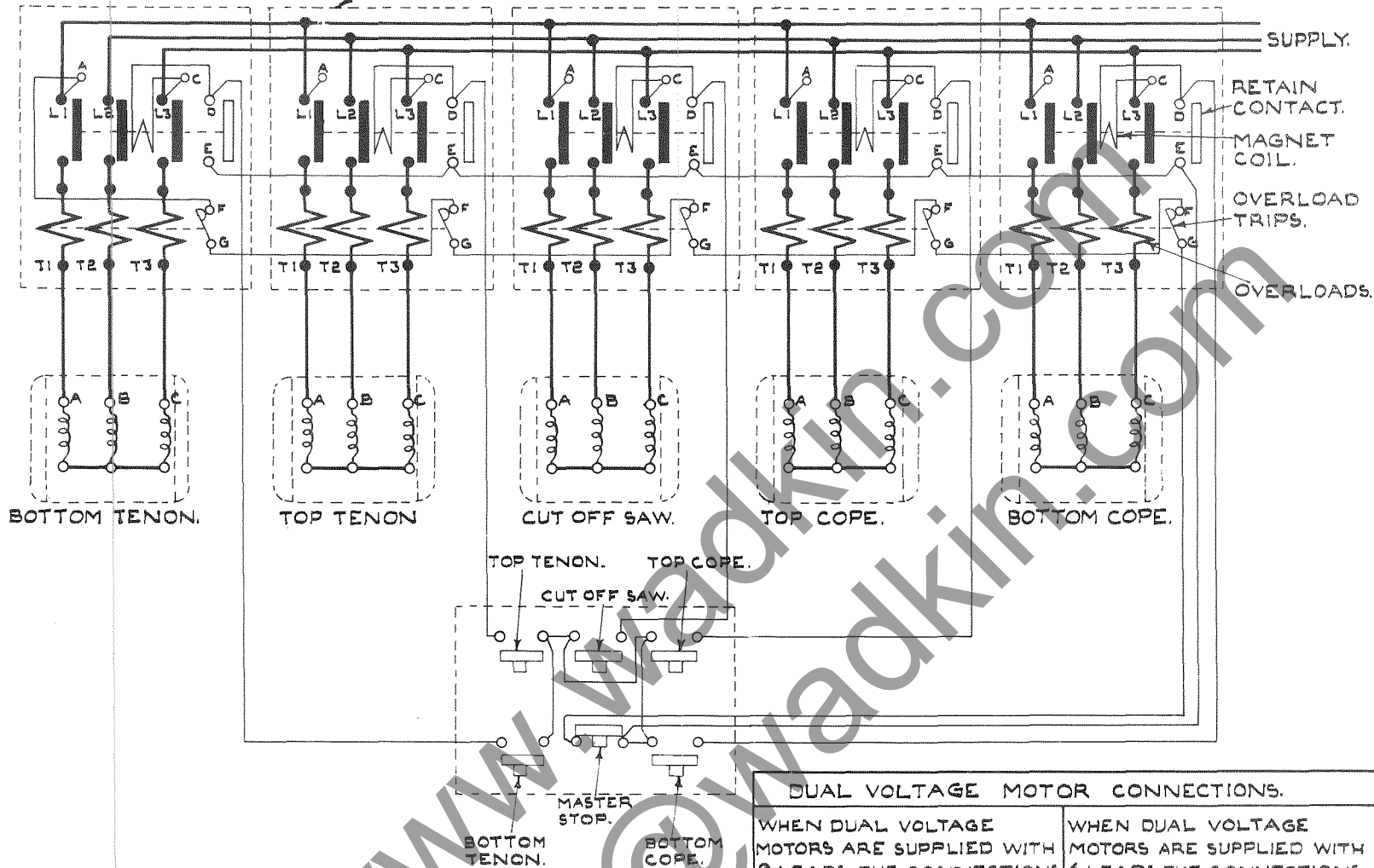

INSTALLATION INSTRUCTIONS.

FIT MAIN DISCONNECT SWITCH NEAR MACHINE SO THAT THE ELECTRICAL GEAR MAY READILY BE ISOLATED FOR INSPECTION PURPOSES. BRING SUPPLY CABLES TO MAIN DISCONNECT SWITCH AND TO L1, L2, L3 AT MAGNETIC STARTERS THROUGH CONDUIT WHICH SHOULD BE SCREWED INTO THE MACHINE AND SECURED BY MEANS OF LOCKNUTS. ENSURE THAT THE DIRECTION OF ROTATION OF THE MOTORS IS CORRECT BEFORE PUTTING THE MACHINE INTO SERVICE, TO REVERSE ROTATION INTERCHANGE SUPPLY CABLES L1 AND L3.

OVERLOAD.

SHOULD THE MACHINE STOP DUE TO OVERLOAD, WAIT FOR A SHORT TIME TO ALLOW THE HEATER COILS TO COOL THEN RESET THE TRIPS BY DEPRESSING THE PLUNGER ON THE OVERLOAD ASSEMBLIES.

DUAL VOLTAGE MOTOR CONNECTIONS.

WHEN DUAL VOLTAGE MOTORS ARE SUPPLIED WITH 9 LEADS THE CONNECTIONS SHOWN BELOW ARE NECESSARY:-		WHEN DUAL VOLTAGE MOTORS ARE SUPPLIED WITH 6 LEADS THE CONNECTIONS SHOWN BELOW ARE NECESSARY:-	
SERIES/STAR-440 VOLTS.	PARALLEL/STAR-220 VOLTS.	STAR - 340/440 VOLTS.	DELTA - 200/250 VOLTS.
TO T1-T2-T3 AT STARTER.	TO T1-T2-T3 AT STARTER	TO T1-T2-T3 AT STARTER	TO T1-T2-T3 AT STARTER
SERIES/STAR	PARALLEL/STAR	STAR.	DELTA.
9 LEAD MOTORS.		6 LEAD MOTORS.	

ELECTRICAL INSTALLATION INSTRUCTIONS

The cabling between the motor and the control gear has been carried out by Wadkin Ltd., and it is only necessary to bring the line leads to the machine for it to be put into service. This should be done as follows :-

- (1) Fit triple pole isolating switch near the machine, unless this has been supplied to special order by Wadkin Ltd., when it will be fitted and connected up at the machine.
- (2) Connect the line lead to the appropriate terminals, see diagram. The cables should be taken to the machine in conduit and secured to the control gear by means of locknuts.
- (3) Connect solidly to earth.
- (4) Close isolating switch and press start button. If machine does not rotate in the right direction, interchange any two incoming line leads.

FAILURE TO START

- (1) Electric supply is not available at the machine.
- (2) Fuses have blown or have not been fitted.
- (3) Isolating switch has not been closed.
- (4) Lock-off or stop button has not been released.

STOPPAGE DURING OPERATION AND FAILURE TO RESTART

- (1) Fuses have blown.
- (2) Overloads have tripped. They will reset automatically after a short time, and the machine can be restarted in the usual manner.

ADJUSTMENT

For a finer overload setting, set the load indicator to a lower value, and vice-versa for a less fine setting.

GENERAL

Check the earth connection from time to time. Users are recommended to display in an appropriate position in the maintenance department Wadkin Electrical Maintenance Instruction Card, No. 356, which is issued gratis on application.

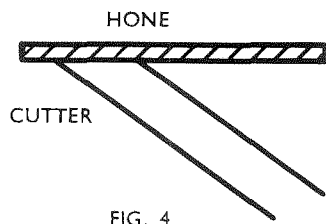

FIG. 4

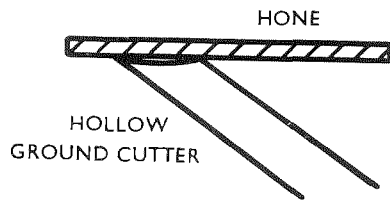

FIG. 5

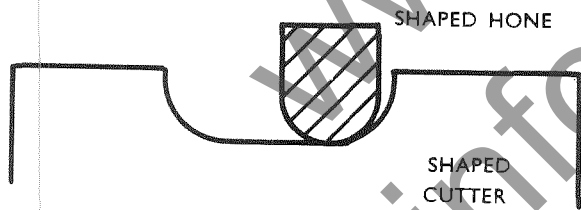

FIG. 6

HONING.

Cutters must have a razor sharp cutting edge before commencing to cut. To obtain this edge it is necessary to hone the cutters using a 142 carborundum slip stone. This will ensure a good finish on the wood and an easy feed. Dull cutters give a poor, rough and plucked out finish and make it difficult to feed the job past the cutters. Honing should be done by a reciprocating or rotary motion on the cutter, using a little paraffin to give "bite" to the stone. The honing stone is a much finer grit than the grindwheel and leaves a sharp keen edge. A number of honing stones of different shapes, e.g. round or square sticks will be found helpful in honing shaped cutters.

TENON BLOCK ADZE CUTTER GRINDING ATTACHMENT (Continued)

Take an initial roughing cut of one or one-and-a-half thousandths of an inch on one knife, turn the block round to the next knife and take the same cut, proceeding thus until both knives have been ground. After grinding completely round the block, take successive light roughing cuts until both knives are sharpened. On the roughing cuts use a rapid table traverse. On the finishing pass, reduce the cut to one-half thousandth of an inch and use a slow table traverse to ensure a keen cutting edge and uniform blade height. Finally check the setting of the knives on the tenon block setting stand.

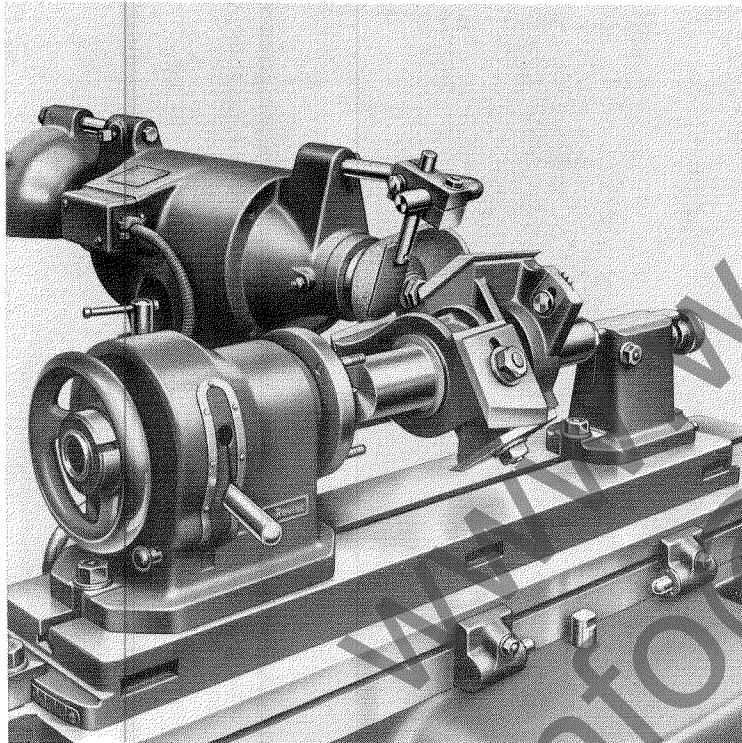

FIG. 29. Showing the tenon blocks set up for grinding.



FIG. 30. Showing the actual operation of grinding, indicating the best position for the operator.

TENON BLOCK ADZE CUTTER GRINDING ATTACHMENT (Continued)

The finger assembly is now set up as shown in Fig. 25. The tip of the finger should be set approximately $\frac{3}{4}$ " below the centre of the wheel, on the cutting side of the wheel (left-hand side with the wheel running clockwise) and $\frac{1}{32}$ " away from the wheel as shown in diagram Fig. 26.

Generally, tenon blocks are made slightly conical and due to this the swivelling table must be set over to give this coned effect, as shown exaggerated in Figs. 27 and 28. The amount that the table is set over depends upon the make of block, but for Wadkin blocks the amount is one division of the scale on the left-hand side of the swivelling table, equal to a movement of $\frac{1}{16}$ ".

The direction in which the table is set over depends upon which way the block is coned. On all Wadkin blocks the spur cutter end of the block is the bigger diameter, therefore the settings are as shown in Figs. 27 and 28.

NOTE. - It is recommended that when a block has been ground, tried on the setting-up stand and found correct, that the position of the swivelling table relative to the machine table be marked by scribe lines to facilitate easier and quicker set-ups for subsequent regrinds.

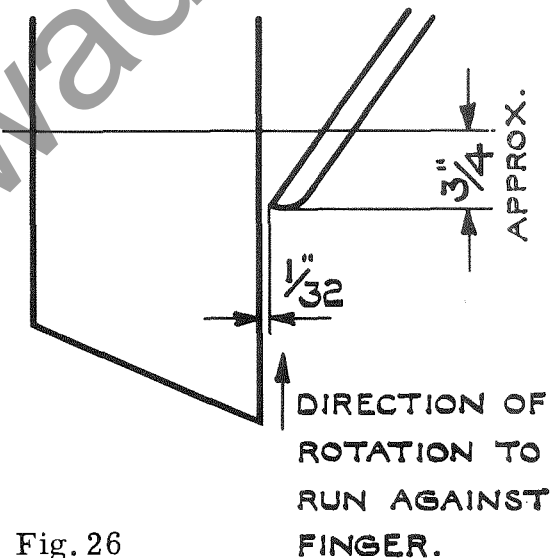
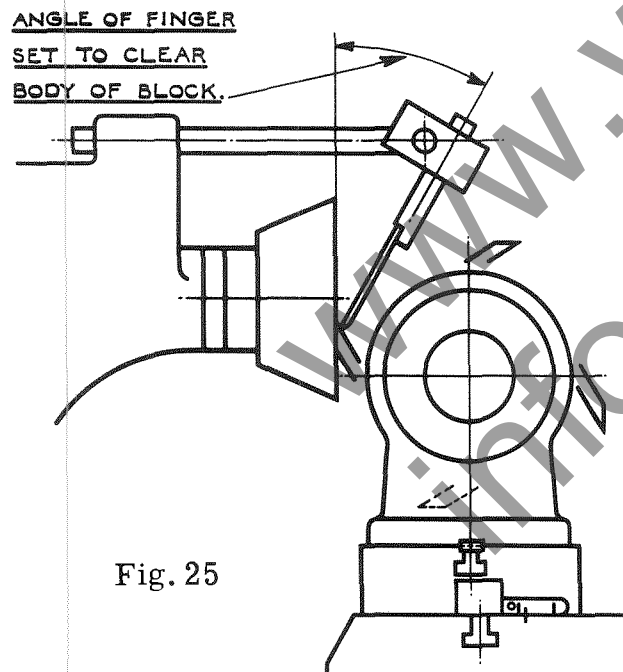

CUTTER EQUIPMENT

INSERTED TOOTH GROOVING SAWS

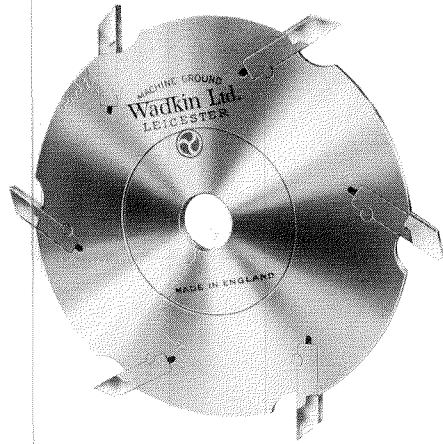
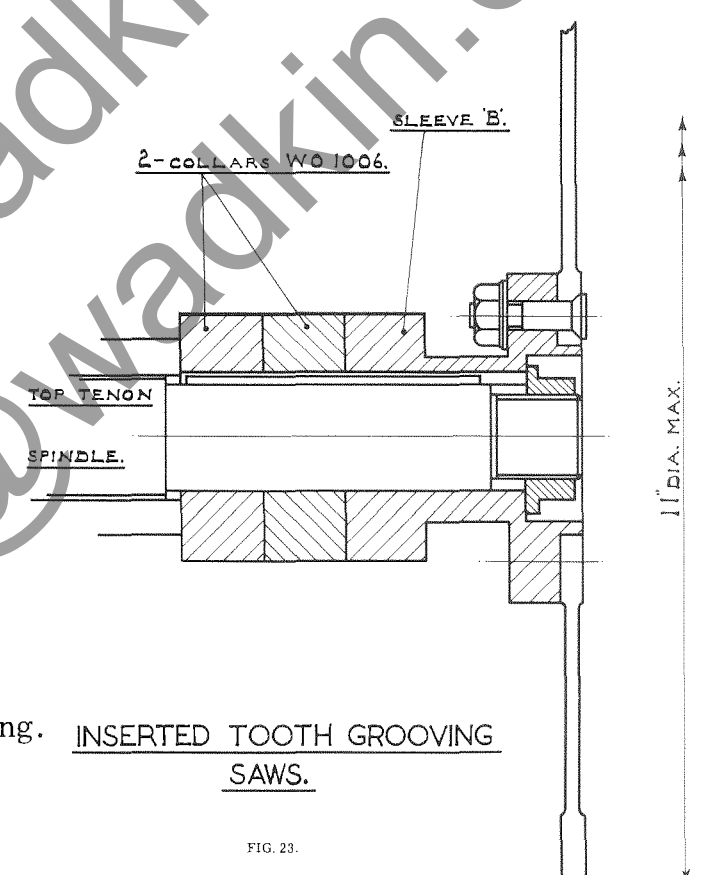
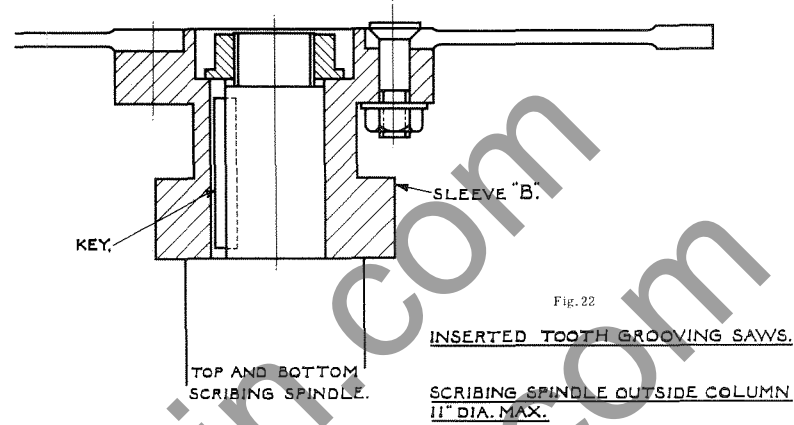

FIG. 21

High speed steel inserted tooth grooving saws are supplied for working of narrow grooves, i. e. $\frac{1}{8}$ " up to approximately $\frac{1}{2}$ " wide, where an accurate and clean groove is required. The saws have a very long life and the teeth can be renewed when worn out. Where necessary Tungsten Carbide tipped saws can be supplied for working plywood, etc.

An inserted tooth grooving saw fitted on the top tenon spindle is shown in Fig. 22. A spacing collar and a sleeve are provided when this saw is supplied. A similar set up can be fitted on either the top or bottom scribing spindles as shown in Fig. 23. Set ups can be supplied to suit customers own particular work, in which case samples or a dimensioned sketch of work to be produced should be sent to us when enquiring.



INSERTED TOOTH GROOVING SAWS.

FIG. 23.

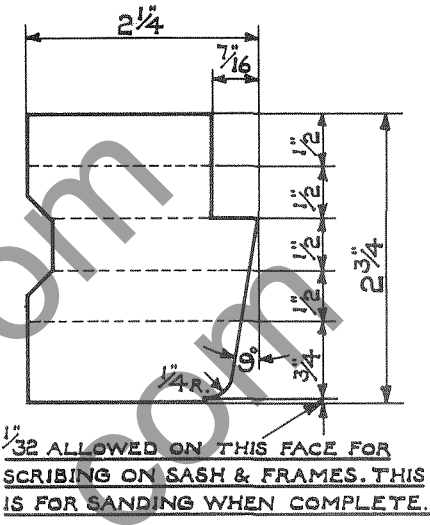
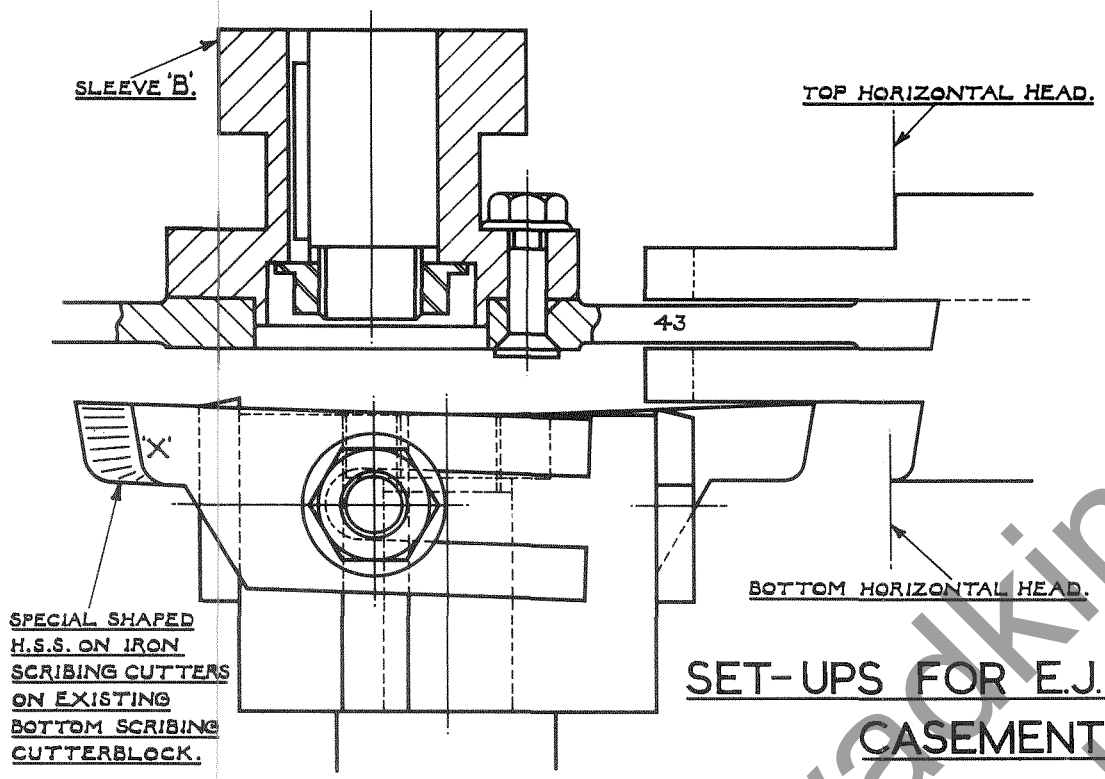

SET-UPS FOR E.J.M.A. HEAVY TYPE CASEMENT WINDOWS.

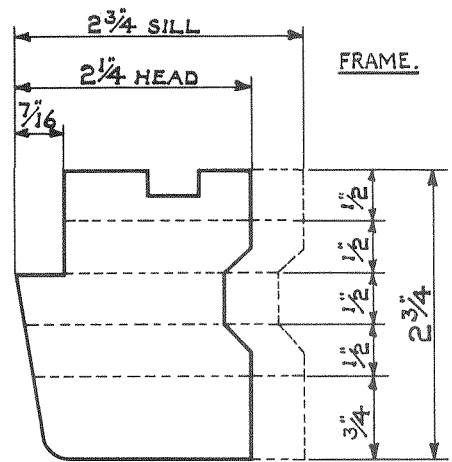
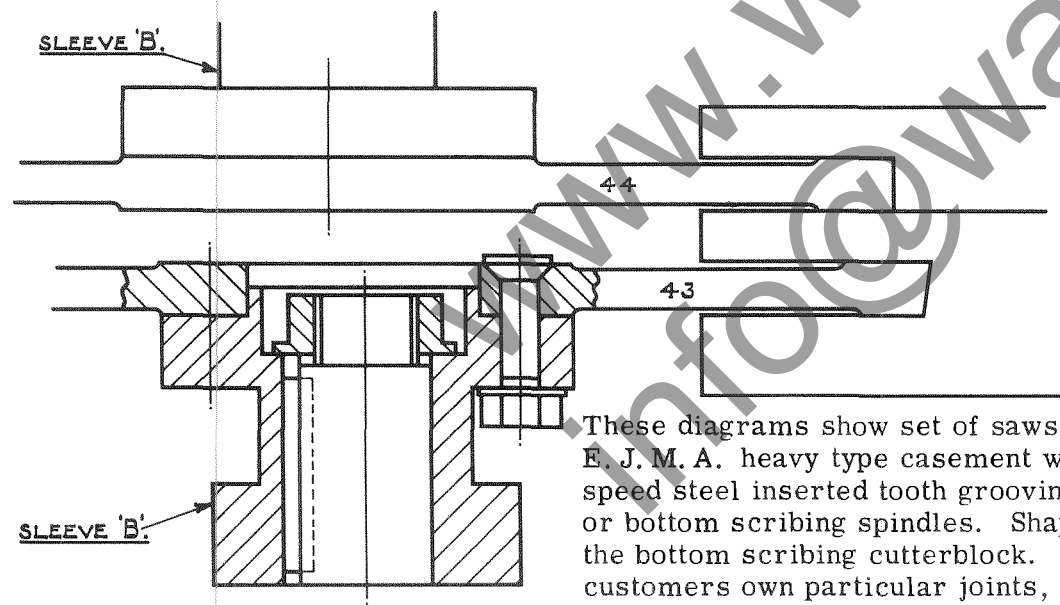

Fig. 20

These diagrams show set of saws and cutters for working frames and sashes of E. J. M. A. heavy type casement windows. The grooving is worked using high speed steel inserted tooth grooving saws mounted on special sleeves fitted on top or bottom scribing spindles. Shaped scribing cutters can be supplied for use on the bottom scribing cutterblock. Complete set ups can be supplied to suit customers own particular joints, please send detailed sketch or samples when enquiring.

CUTTER EQUIPMENT

TRENCHING AND GROOVING HEADS.

A heavy type wobble saw unit fitted on the bottom scribing spindle is shown in Fig. 15. The saw is 10" in diameter and is fitted on a screwed sleeve which is secured to the spindle by a single locknut. The wobble saw unit can be quickly adjusted for cutting grooves between the limits $\frac{1}{8}$ " full to $1\frac{3}{4}$ " wide and a maximum depth of $2\frac{1}{2}$ ".

Two types of wobble saw unit as shown in Figs. 16 and 17 for fitting on top tenon spindles can be supplied.

The heavy type wobble saw unit with a screwed sleeve is mounted on the spindle as shown in Fig. 16. This wobble saw unit with a maximum diameter of 8" can be quickly adjusted for cutting grooves between the limits of $\frac{1}{8}$ " full to $1\frac{7}{16}$ " wide.

The light type wobble saw unit is accommodated on the spindle as shown at Fig. 17, two making up collars being required. The light type has a maximum diameter of 8". Grooves between the limits of $\frac{1}{8}$ " full to $1\frac{1}{8}$ " wide can be cut.

The wobble saw is used when it is not necessary to have a fine finish with clean shoulders in the grooves and where the bottom of the grooves do not need to be flat.

EQUIPMENT 1-SLEEVE L.H. THD. Q M 10, MODIFIED TO S D 4655
1-10" DIA. WOBBLE SAW.

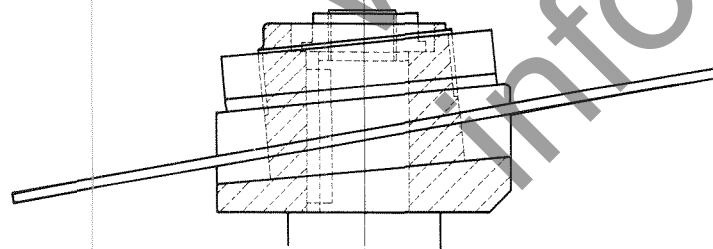

Fig. 15

**HEAVY TYPE
WOBBLE SAW UNIT FITTED ON BOTTOM SCRIBING SPINDLE.**

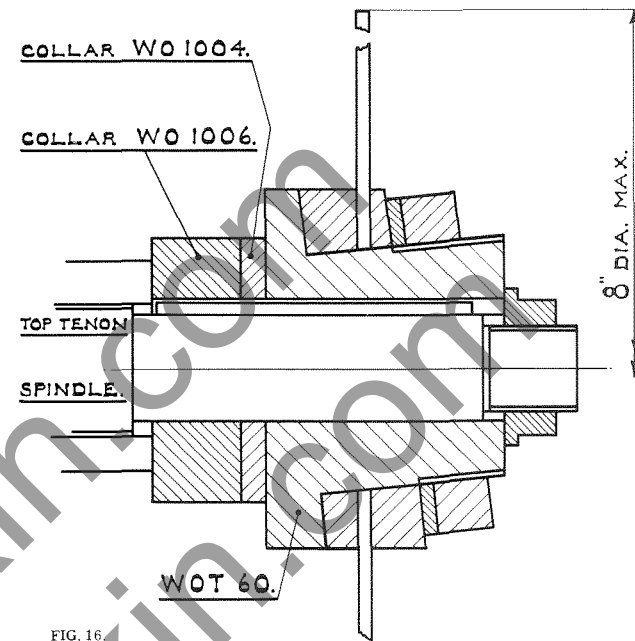

FIG. 16.

HEAVY TYPE WOBBLE SAW.

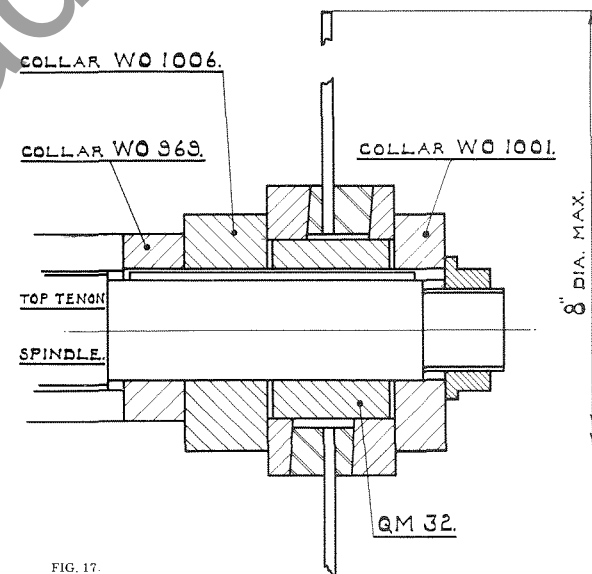

FIG. 17.

LIGHT TYPE WOBBLE SAW.

CUTTER EQUIPMENT

TENONING CUTTERHEADS.

Two tenon cutterheads are supplied as standard equipment complete with High Speed Steel on Iron adze cutters and high chrome steel spur cutters.

		Adze cutter	Spur cutter
Top tenon cutterhead	Part No. EC182	1-pr. EC176	1-pr. EK155
Bottom tenon cutterhead	Part No. EC183	1-pr. EC177	1-pr. EK155

SCRIBING OR COPE CUTTERHEADS.

The cutterblocks are 4.1/16" square section dovetail slotted, and are supplied complete with one pair of High Speed Steel on Iron scribing cutters per block, also four dovetail head cutterbolts.

	Part No.	Cutters
Top scribing cutterhead	EKA182	VM4
Bottom scribing cutterhead	EM244	VM3

Spare dovetail headed bolts for use with scribing cutterblocks - Part No. QW5 with nuts QAF24 and washers QAF46.

DETAILS OF CUTTERBLOCK

CUTTERBLOCKS	Cutting circle		
	Normal	Mini- mum	Maxi- mum
Standard tenon cutterblock	$6\frac{3}{4}$ "	-	-
Square block on tenon head	$7\frac{1}{4}$ "	$6\frac{3}{4}$ "	$8\frac{1}{2}$ "
Square block on scribing head	$7\frac{1}{4}$ "	$6\frac{3}{4}$ "	9"

For range of cutters suitable for scribing blocks see VM range in Section C, Page 10, of our Tools and Accessories Catalogue No. 745.

CUT OFF SAW.

Standard cut off saw supplied for use on this machine is 12" diameter, Part No. QS2.

SCRIBING OR COPE SPINDLE ASSEMBLY

METHOD OF DISMANTLING TO FIT NEW BEARINGS, REAR BEARING.

1. Remove bearing end cover 'A', Fig.11
2. Loosen countersunk head screw in ball bearing locknut 'B' and remove locknut from shaft.
3. Remove rear bearing housing 'C' complete with bearing.
4. Knock out bearing from housing and fit replacement.
5. Reverse dismantling operations to re-assemble.

FRONT BEARING.

6. Remove rear end cover and locknut as operations 1 and 2.
7. Remove front bearing end cover 'D' and remove bearing housing screws.
8. Withdraw shaft from cutterblock end of housing and remove grease retainer 'E' and bearing housing 'F'.
9. Knock out taper pin from rotor retaining collar 'G' and remove collar and rotor from shaft.
10. Loosen countersunk head screw in front ball bearing locknut 'H' and remove locknut and grease retainer 'J' from shaft.
11. Remove bearing from shaft and fit replacement.
12. Reverse dismantling operations to re-assemble.

TO REMOVE STATOR FROM FRAME.

Remove $\frac{1}{4}$ " gas pipscrew 'K' from stator frame and knock out stator.

IMPORTANT.

When replacing stator, care must be taken to avoid drilling into the windings. Maximum depth of pipscrew hole is $\frac{5}{16}$ " to the tip of the drill.

BOTTOM SCRIBING SPINDLE E. C. 129.

Thread 'L' 1" fine thread 14 T.P.I. R.H.

Thread 'M' $1\frac{3}{4}$ " fine thread 14 T.P.I. R.H.

Thread 'N' 1" fine thread 14 T.P.I. L.H.

TOP SCRIBING SPINDLE E. O. 312.

Thread 'L' 1" fine thread 14 T.P.I. L.H.

Thread 'M' $1\frac{3}{4}$ " fine thread 14 T.P.I. L.H.

Thread 'N' 1" fine thread 14 T.P.I. R.H.

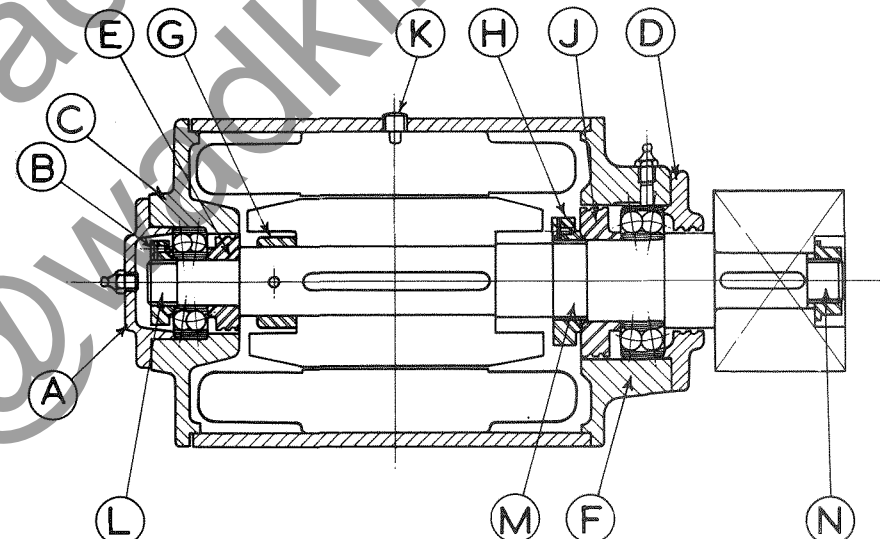

SCRIBING OR COPE SPINDLE ASSEMBLY.

Fig. 11

BALL BEARING LIST

Makers Number	Size			Number Per Machine	Where used on machine
	Bore	Outside Diameter	Width		
SKF. 2206	30 mm	62 mm	20 mm	2	1 - Top tenon spindle 1 - Bottom tenon spindle
SKF. 2208	40 mm	80 mm	23 mm	3	1 - Driving end top tenon head 1 - Driving end bottom tenon head 1 - Driving end cut off saw
SKF. 2209	45 mm	85 mm	23 mm	4	1 - Non-driving end top tenon head 1 - Non-driving end bottom tenon head 1 - Driving end top scriber 1 - Driving end bottom scriber
SKF. RM8	1"	2 $\frac{1}{2}$ "	$\frac{3}{4}$ "	3	1 - Non-driving end top scriber 1 - Non-driving end bottom scriber 1 - Non-driving end cut off saw
SKF. RLS6	$\frac{3}{4}$ "	1 $\frac{7}{8}$ "	9/16"	4	Spindle for table rollers
SKF. 08 Thrust washer	1"	1 $\frac{3}{4}$ "	$\frac{5}{8}$ "	2	1 - Top tenon raising screw 1 - Bottom tenon raising screw

THE TABLE.

The table is mounted on four ball bearing rollers. If due to wear there is any play in the table the nuts 'Z', Fig. 2, should be tightened, so that perfect alignment with the cutterblocks is always maintained.

The centre sliding table is locked in position by locking handle 'V', Fig. 3. A spring stop runs the full length of the sliding table and is released into position by loosening the wing nuts which hold the stop under the table. On both sides of the sliding table a channel is cut so that the stop may be fitted in two positions. The springs have to be retained in position whilst transferring the stop.

A lever cramp is provided which can be adjusted for various widths and thicknesses of work by screwing the two locknuts 'W', Fig. 3, either up or down as necessary.

TABLE FENCE.

The table fence is provided with a turn over stop. The fence can be set at angles 0° to 45° by means of the series of holes tapped in the back table and secured by locking nut 'X', Fig. 3.

DEAD STOP AND TURNOVER STOP.

A dead stop is provided for use in conjunction with the turn over stop on the fence. This stop is for locating the work of producing tenons in order to cut the tenon off the correct length. To complete the tenons at both ends of the work the material is turned round and positioned for correct length by use of the turn over stop on the fence. When this operation is carried out the dead stop can be allowed to fall down so that it is clear of the work by unlocking locking handle 'Y', Fig. 3. The dead stop is adjustable for length of material along a bar and can be locked where desired. Similarly the turn over stop is adjustable along a rod.

SLIDING TABLE.

The sliding table is provided with a spring stop running the full length for the purpose of loading the table with narrow stock, such as sash bars. The stop can be placed in either of the two grooves in the table to accommodate any length of stock.

TENONING HEAD SPINDLE END.

The spindle end is shown in Fig. 6. The cutter-blocks are driven with the key and locked in position with hexagon nut. A special box spanner is provided for locking the nut. Two holes in the cutterblock are used to take a tommy bar to hold the spindle while locking the nut.

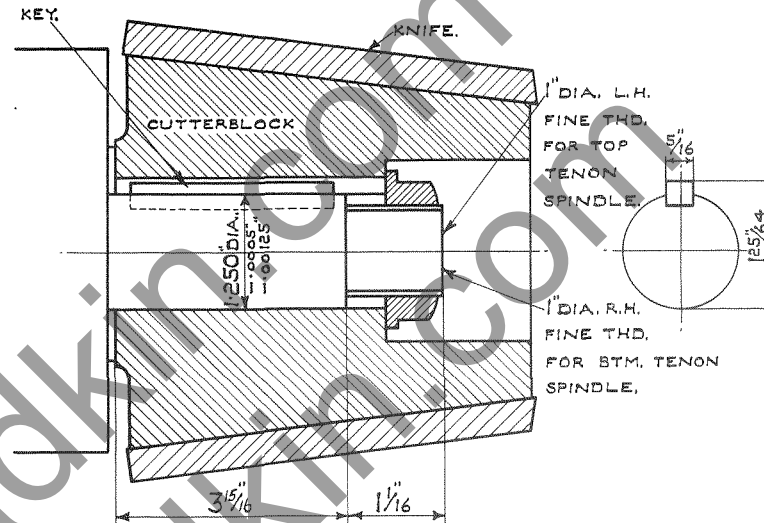

FIG. 6. TENONING HEAD SPINDLE END.

TOP SCRIBING OR COPE HEAD.

The top scribing head is carried on a slideway fixed to the top tenoning head and will therefore move up and down when the tenoning head is adjusted. Further vertical adjustment to the scribing head is obtained by rotating star handwheel 'L', Fig. 3. This movement is locked by tee locking handle 'M', Fig. 3. Cross adjustment to the scribing head is obtained by rotating star handwheel 'P', Fig. 2, which is locked by locking handle 'Q', Fig. 3.

BOTTOM SCRIBING OR COPE HEAD.

The bottom scribing head is mounted and operated similar to the top head with its main adjustment taken from the bottom tenoning head. Further vertical adjustment to the head is taken from star handwheel 'N', Fig. 2, and is locked with the tee locking handle 'O', Fig. 3. Cross adjustment is provided by rotating star handwheel 'R', Fig. 2, and locked with locking handle 'S', Fig. 3.

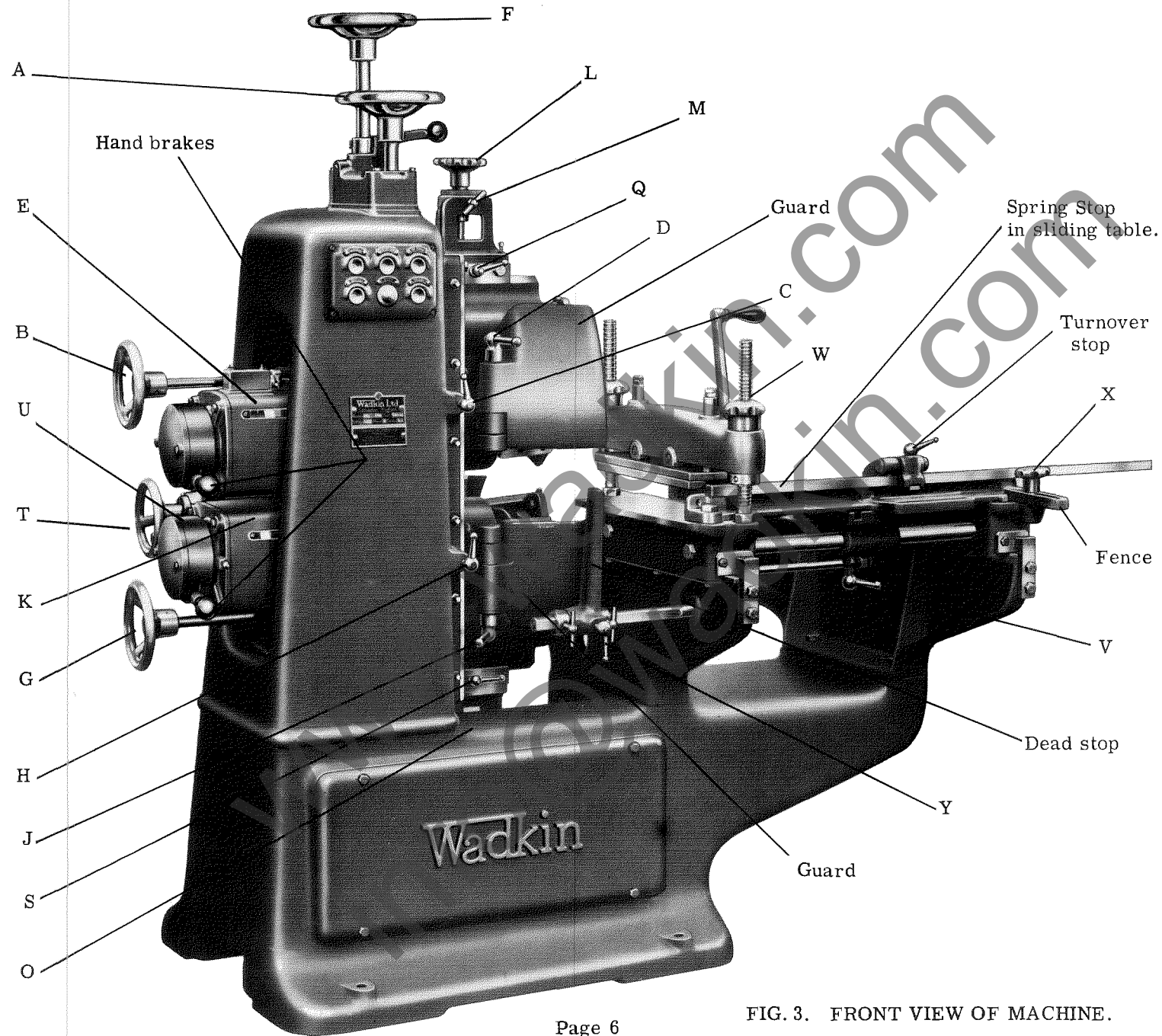

FIG. 3. FRONT VIEW OF MACHINE.

INSTALLATION.

The machine is despatched from the Works with all bright surfaces greased to prevent rusting. This must be removed by applying a cloth damped in paraffin or turpentine.

FOUNDATIONS.

Rag bolts 5/8" (16 mm) diameter should be used to fix the machine to the floor, but these are not supplied by Wadkin Ltd. unless specially ordered. If the mill floor consists of 4" (100 mm) to 6" (150 mm) solid concrete no special foundation is necessary. The outline in Fig. 1 gives details of bolt positions and clearances required. Cut 6" (150 mm) to 8" (200 mm) square holes in the concrete and run with liquid cement to fix. The machine should be carefully levelled before fixing and again after final fixing to ensure that no distortion has taken place.

WIRING.

For complete cabling instructions and wiring diagrams see pages 30 to 32.

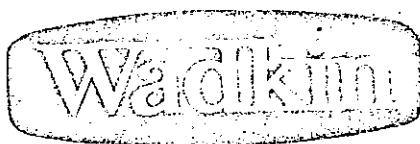

SPARE PARTS BOOKLET

CONTENTS

1. Basic ordering requirements.
2. Sample type order.
3. List of item numbers and description of item.
4. Drawing showing item numbers.

ECA
SINGLE END TENONING
MACHINE

SPARE PARTS

Should spare parts be required due to breakage or wear full particulars including the machine and test number must be given. This information is on the nameplate attached to the machine and will be similar to the picture below.

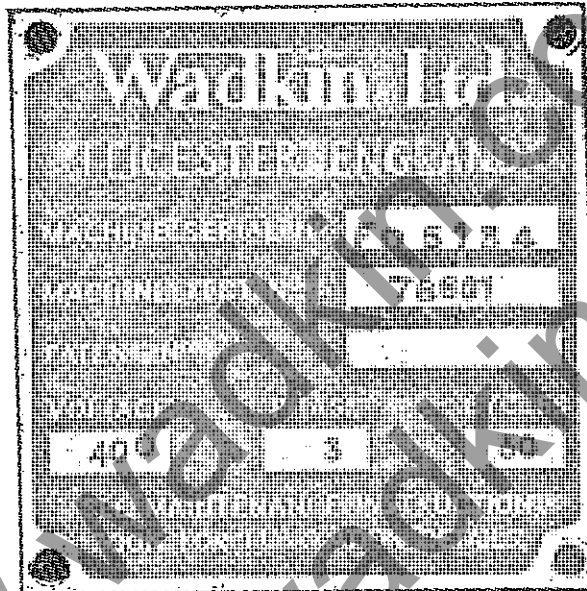

Please see the next page for sample detail of how to order spare parts.

SAMPLE TYPE ORDER

MACHINE: ECA

MACHINE NO: 1407

TEST NO: 68975

PARTS REQUIRED

1 - EC250/EC8 FENCE
1 - EC250/EC32 SLIDE FOR TOP TENON
1 - EC250/EC70 GEAR
1 - EC250/EC126 SPRING FOR CRAMP PLATE
1 - EC250/EC215 SPACING COLLAR

ECA SPARE PARTS LIST

EC250/EC1/A	BASE
EC250/EC3	L.H. TABLE WAY
EC250/EC4	R.H. TABLE WAY
EC250/EC5	L.H. TABLE
EC250/EC6	R.H. TABLE
EC250/EC7	SLIDING TABLE
EC250/EC8	FENCE
EC250/EC9	COVER FOR BASE (CONTACTOR)
EC250/EC10	SLIDE FOR CUT OFF SAW
EC250/EC11	FRONT END COVER FOR TENON HEAD
EC250/EC12	PILLAR
EC250/EC20	BRIDGE FOR DUPLEX ELECTRIC CLAMP
EC250/EC21	ECCENTRIC FOR DUPLEX ELECTRIC CLAMP
EC250/EC22	ADJ. CLAMP
EC250/EC23	CLAMP HANDLE
EC250/EC32	SLIDE FOR TOP TENON
EC250/EC33	SLIDE FOR BOTTOM TENON
EC250/EC38/A	GEAR BRACKET
EC250/EC49	TOP TENON SPINDLE
EC250/EC50	BOTTOM TENON SPINDLE
EC250/EC55	BEARING HOUSING
EC250/EC56	BEARING HOUSING
EC250/EC57	STATOR FRAME
EC250/EC70	GEAR
EC250/EC72	IDLER GEAR SHAFT
EC250/EC73	OPERATING LEVER
EC250/EC74	VERT. ADJ. SCREW (TOP TENON)
EC250/EC75	VERT. ADJ. SCREW (BOTTOM TENON)
EC250/EC76	HEX HD SCREW FOR GEAR BRACKET
EC250/EC78	HANDWHEEL SHAFT

EC250/EC79	GREASE RETAINER
EC250/EC80	BRAKE DRUM
EC250/EC81	PIVOT PIN FOR OPERATING LEVER
EC250/EC82	PIN FOR IDLER GEAR SHAFT
EC250/EC83	BUSH FOR IDLER SHAFT
EC250/EC84	WASHER FOR IDLER SHAFT
EC250/EC96	GUARD FOR CUTTERBLOCK
EC250/EC97	GUARD FOR CUTTERBLOCK
EC250/EC101	STAYBOLT FOR TABLE WAYS
EC250/EC102	TABLE ROLLERS
EC250/EC103	END CAP FOR TABLE ROLLERS
EC250/EC104	BUSH FOR TABLE ROLL SPINDLE
EC250/EC105	SPINDLE FOR TABLE ROLLERS
EC250/EC106	LIP PLATE FOR TABLE
EC250/EC107	GUIDE STRIP FOR TABLE
EC250/EC108	STOP STRIP FOR SLIDING TABLE
EC250/EC110	STOP BAR
EC250/EC111	TABLE STOP
EC250/EC112	FLAT SCRAPER
EC250/EC113	SHAFT FOR END STOP
EC250/EC114	FELT FOR SCRAPERS
EC250/EC115	HORIZONTAL ADJUSTING SCREW FOR BOTTOM SCRIBER
EC250/EC120	STUD FOR CRAMP PLATE
EC250/EC121	SLEEVE FOR STUD
EC250/EC122	CONNECTING LINK
EC250/EC123	PIN FOR CONNECTING LINK
EC250/EC124	FULCRUM PIN (5- $\frac{3}{8}$ " LONG)
EC250/EC125	FULCRUM PIN (3- $\frac{3}{8}$ " LONG)
EC250/EC126	SPRING FOR CRAMP PLATE
EC250/EC127	CRAMP PLATE
EC250/EC128	RUBBER PRESSURE STRIPS
EC250/EC129	BOTTOM SCRIBER SPINDLE

EC250/EC132	LOCKNUT FOR TOP TENON SPINDLE
EC250/EC133	LOCKNUT FOR BOTTOM TENON SPINDLE
EC250/EC176	5" TENON CUTTER (TOP HEAD)
EC250/EC177	5" TENON CUTTER (BOTTOM HEAD)
EC250/EC182	TENON HEAD FOR 5" LONG TENONS (TOP)
EC250/EC183	TENON HEAD FOR 5" LONG TENONS (BOTTOM)
EC250/EC205	HINGE PLATE FOR GUARD
EC250/EC209	HINGE PIN FOR GUARD
EC250/EC215	SPACING COLLAR
EC250/EH13	NUT FOR TRAVERSE OF SPINDLE HOUSING
EC250/EH17/A	SPINDLE HOUSING FOR TOP TENONING HEAD
EC250/EH18/A	SPINDLE HOUSING FOR BOTTOM TENONING HEAD
EC250/EH29	COVER FOR STATOR FRAMES
EC250/EH32	HORIZONTAL INDICATOR (T & B HEADS)
EC250/EH34	SLIP COVER - FRONT
EC250/EH35	SLIP COVER - REAR
EC250/EH36	WEAR STRIP
EC250/EH37	PIN FOR TOP AND BOTTOM CUTTER GUARDS
EC250/EH63/A	STOP HOLDER
EC250/EH65	GREASE RETAINER FOR TENONING SPINDLES
EC250/EH88/A	UPPER SAW GUARD (BELOW TABLE)
EC250/EH91/A	LOWER SAW GUARD FOR C/O SAW BELOW TABLE
EC250/EH92	SAW SPINDLE
EC250/EH99/A	INTERMEDIATE SLIDE FOR TOP SCRIBER
EC250/EH100	INTERMEDIATE SLIDE FOR BOTTOM SCRIBER
EC250/EH102/A	FRONT MOTOR COVER
EC250/EH103/A	REAR MOTOR COVER
EC250/EH104	SLIDE BRACKET
EC250/EH105	FRONT END COVER
EC250/EH106	REAR END COVER

EC250/EH122 VERTICAL TRAVERSE SCREW FOR TOP SCRIBER
EC250/EH123 HORIZONTAL ADJUSTING SCREW
EC250/EH126 MODIFICATION TO TENONING SPINDLE

EC250/EJ45 STOP
EC250/EJ91 CLAMP POST
EC250/EJ95 PIVOT PIN FOR FENCE
EC250/EJ97 PIVOT PIN FOR STOP
EC250/EJ99 BOLT

EC250/EK61 STOP
EC250/EK206/A BEARING NUT FOR SCRIBING APPARATUS
EC250/EK233 NUT FOR INTERMEDIATE SLIDE FOR SCRIBING SPINDLE

EC250/EKA4B BOTTOM CUTTER CARRIAGE
EC250/EKA13 BRAKE SHOE
EC250/EKA47 BRAKE BOX
EC250/EKA48 END CAP FOR BRAKE BOX
EC250/EKA62 VEE STRIP FOR CARRIAGE
EC250/EKA68 COLLAR FOR CUTTER SPINDLE
EC250/EKA75 COLLAR FOR CUTTER SPINDLE
EC250/EKA182 TOP SCRIBING CUTTERBLOCK
EC250/EKA252 NUT FOR SAW SPINDLE
EC250/EKA254 STUD FOR OPERATING BRAKE
EC250/EKA319 COLLAR FOR BUSH
EC250/EKA337 PUSH BUTTON PLATE
EC250/EKA338 PUSH BUTTON PLATE

EC250/EL461 VEE STRIP FOR BOTTOM SCRIBER INTER SLIDE

EC250/E023A	STATOR FRAME FOR L.H. CROSS CUT UNIT
EC250/E046A	STATOR FRAME FOR T & B SCRIBERS
EC250/E047	CUTTERBLOCK BEARING HOUSING
EC250/E048	CUTTERBLOCK BEARING END COVER
EC250/E0307	HORIZONTAL SCREW FOR CROSS CUT SAW
EC250/E0312	SPINDLE FOR LEFT TOP SCRIBER

EC250/1A	BALL BEARING LOCKNUT
EC250/1A	TWO BALL HANDLE
EC250/1A	CLAMP NUT LEVER
EC250/1A	SAW COLLAR
EC250/1A	TEE LOCKING HANDLE
EC250/1B	BALL BEARING LOCKNUT
EC250/1B	TWO BALL HANDLE
EC250/1B	CLAMP NUT
EC250/1B	HANDWHEEL
EC250/1B	SAW COLLAR
EC250/1C	TWO BALL HANDLE
EC250/1E	TWO BALL HANDLE
EC250/2	GREASE RETAINER
EC250/2	HORN HANDLE
EC250/2A	BALL BEARING LOCKNUT
EC250/2A	HANDWHEEL
EC250/2A	PIPSCREW
EC250/2A	SLIDE LOCKSCREW
EC250/2B	BALL BEARING LOCKNUT
EC250/2D	STAR HANDWHEEL
EC250/3	COLLAR
EC250/3B	HANDWHEEL
EC250/5	COLLAR
EC250/5B	BALL BEARING LOCKNUT

EC250/7A	BALL BEARING LOCKNUT
EC250/7B	BALL BEARING LOCKNUT
EC250/11A	HANDWHEEL
EC250/62	GREASE RETAINER
EC250/92	GREASE RETAINER
EC250/102	GREASE RETAINER
EC250/AF39	LOCKNUT FOR PIVOT PINS
EC250/CR3	TAIL END HOUSING
EC250/CR4	END CAP FOR TAIL END
EC250/EM244	TOP SCRIBING CUTTERBLOCK
EC250/LM77	BUFFER FOR SLIDE
EC250/ME136	LEVER PLUNGER SPRING
EC250/PC2	OIL NIPPLE
EC250/QS2	12" FLAT CROSS CUT SAW
EC250/RD43	PIVOT PIN
EC250/SKF.08	SKEFCO BEARING
EC250/SKF2206	SKEFCO BEARING
EC250/SKF2208	SKEFCO BEARING
EC250/SKF2209	SKEFCO BEARING
EC250/SKFRL56	SKEFCO BEARING
EC250/SKF.RM8	SKEFCO BEARING
EC250/SSR4	BRASS SCALE $3\frac{1}{4}$ " x $\frac{5}{8}$ " x 20 B.W.G.
EC250/SSR40	BRASS SCALE $3\frac{1}{4}$ " x $\frac{5}{8}$ " x 20 BWG
EC250/WA497	NUT FOR SCRIBER SPINDLE
EC250/WA498	NUT FOR SCRIBER SPINDLE
EC250/YK91	BRAKE LINING

PRINCIPAL DIMENSIONS AND CAPACITIES.	
MOTOR DRIVING HORIZONTAL CUTTER HEADS.	2 H.P.
MOTOR DRIVING TOP AND BOTTOM SCRIBING HEADS.	2 H.P.
MOTOR DRIVING REAR CUT-OFF SAW.	1/2 H.P.
DIAMETER OF HORIZONTAL CUTTER HEADS.	6 1/2" (165 MM.)
DIAMETER OF TOP AND BOTTOM SCRIBING HEADS.	6 1/2" (200 MM.)
DIAMETER OF REAR CUT-OFF SAW.	12" (305 MM.)
DIAMETER OF GROOVING HEADS FOR TOP AND BOTTOM SCRIBERS.	11" (279 MM.)
MAX. LENGTH OF TENON.	5" (127 MM.)
MAX. STOCK SECTION.	1 1/2" x 4 1/2" (38 x 114 MM.)
FENCE WITH SWIVEL TR.	4-5"
HEIGHT OF TABLE FROM FLOOR.	2' 8 1/4" (832 MM.)

1 1/2" x 4 1/2" SINGLE END TENONER TYPE E.C.A.

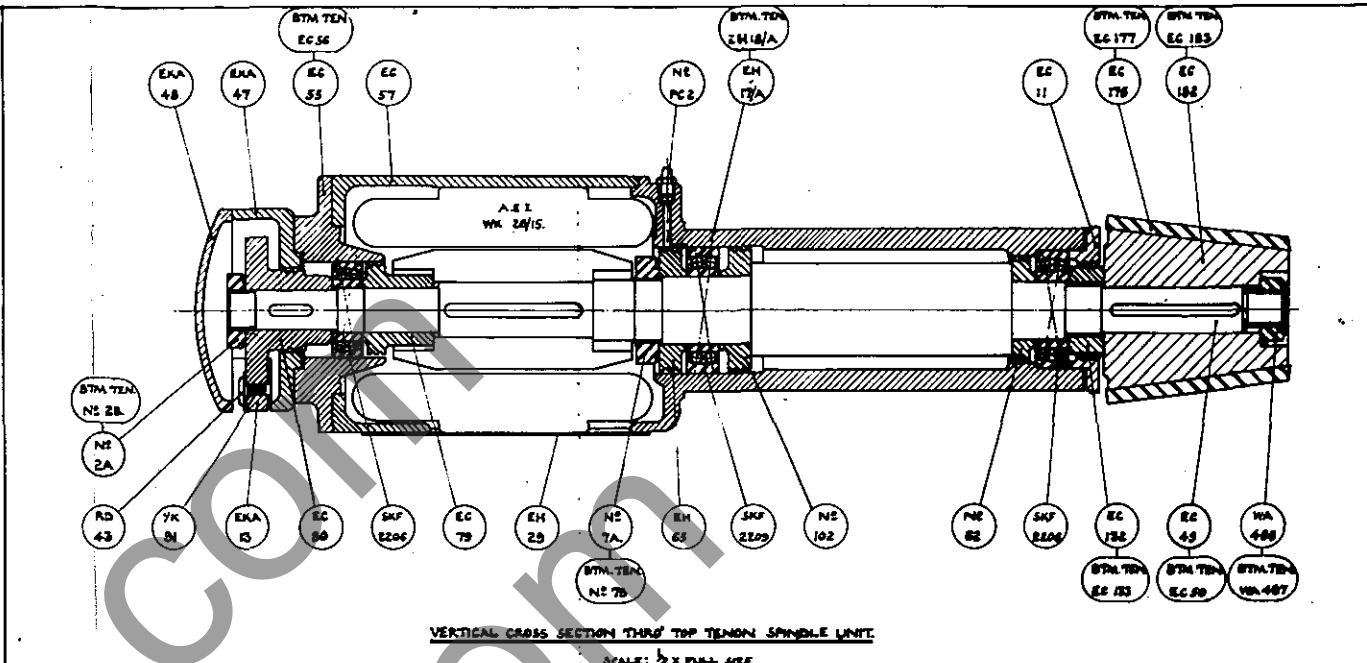

VERTICAL CROSS SECTION THROUGH TOP TENON SPINDLE UNIT
SCALE: 2 X FULL SIZE

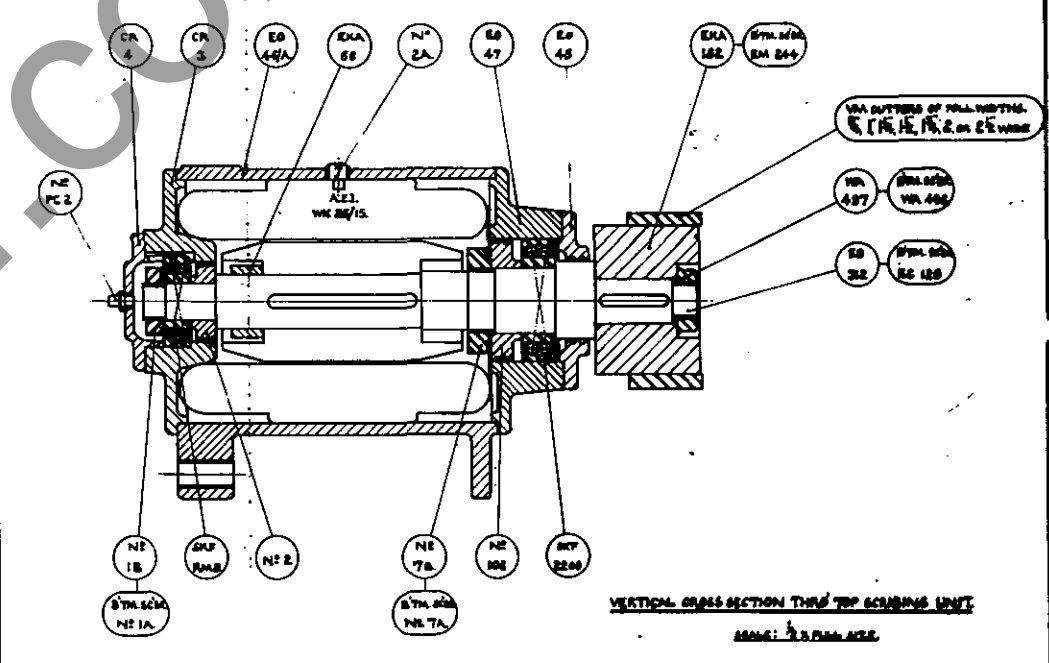

VERTICAL CROSS SECTION THROUGH TOP SCRIBING UNIT
SCALE: 2 X FULL SIZE

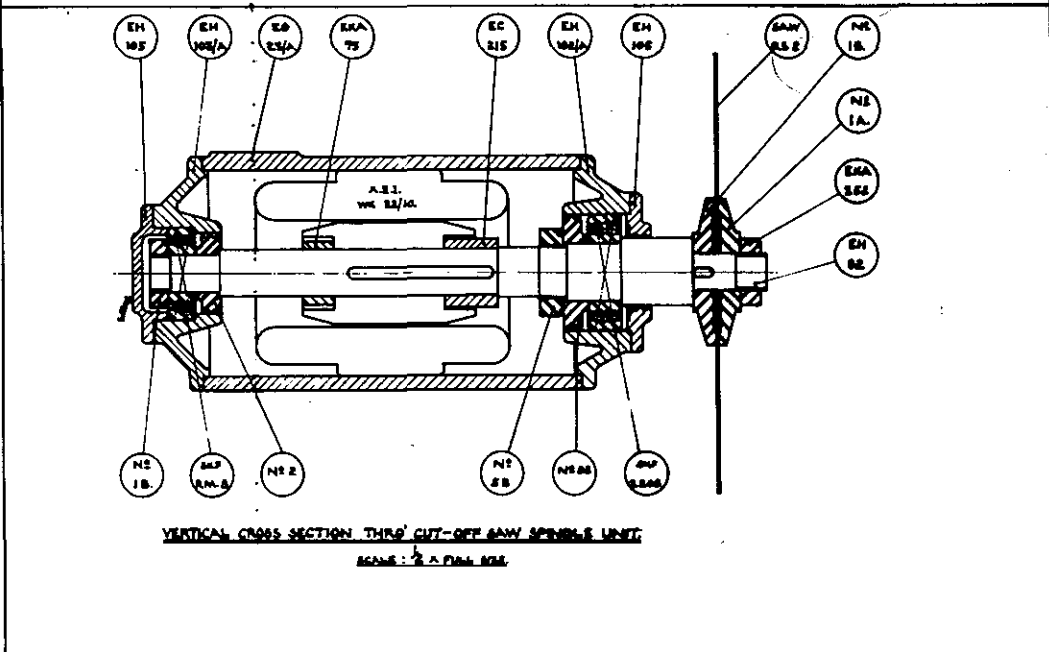

PRINCIPAL DIMENSIONS AND CAPACITIES.	
MOTOR DRIVING HORIZONTAL CUTTER HEADS.	2 H.P.
MOTOR DRIVING TOP AND BOTTOM SCRIBING HEADS.	2 H.P.
MOTOR DRIVING REAR CUT-OFF SAW.	1/2 H.P.
DIAMETER OF HORIZONTAL CUTTER HEADS.	6 1/2" (165 MM.)
DIAMETER OF TOP AND BOTTOM SCRIBING HEADS.	6 1/2" (165 MM.)
DIAMETER OF REAR CUT-OFF SAW.	12" (305 MM.)
DIAMETER OF GADGETS HEADS FOR TOP AND BOTTOM SCRIBERS.	11" (279 MM.)
MAX. LENGTH OF TENON.	5" (127 MM.)
MAX. STOCK SECTION.	14" x 4 1/2" (356 x 114 MM.)
FENCE WILL SWIVEL TO.	45°
HEIGHT OF TABLE FROM FLOOR.	2' 8 3/4" (832 MM.)

14" x 4 1/2" SINGLE END TENONER TYPE ECA.

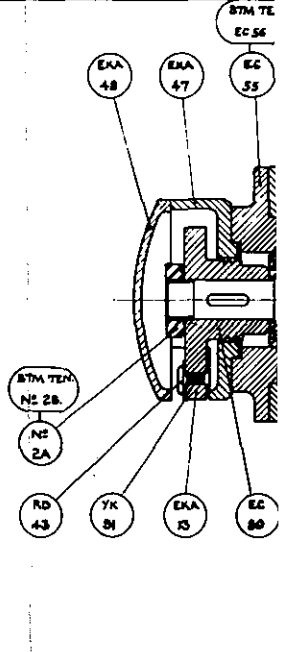
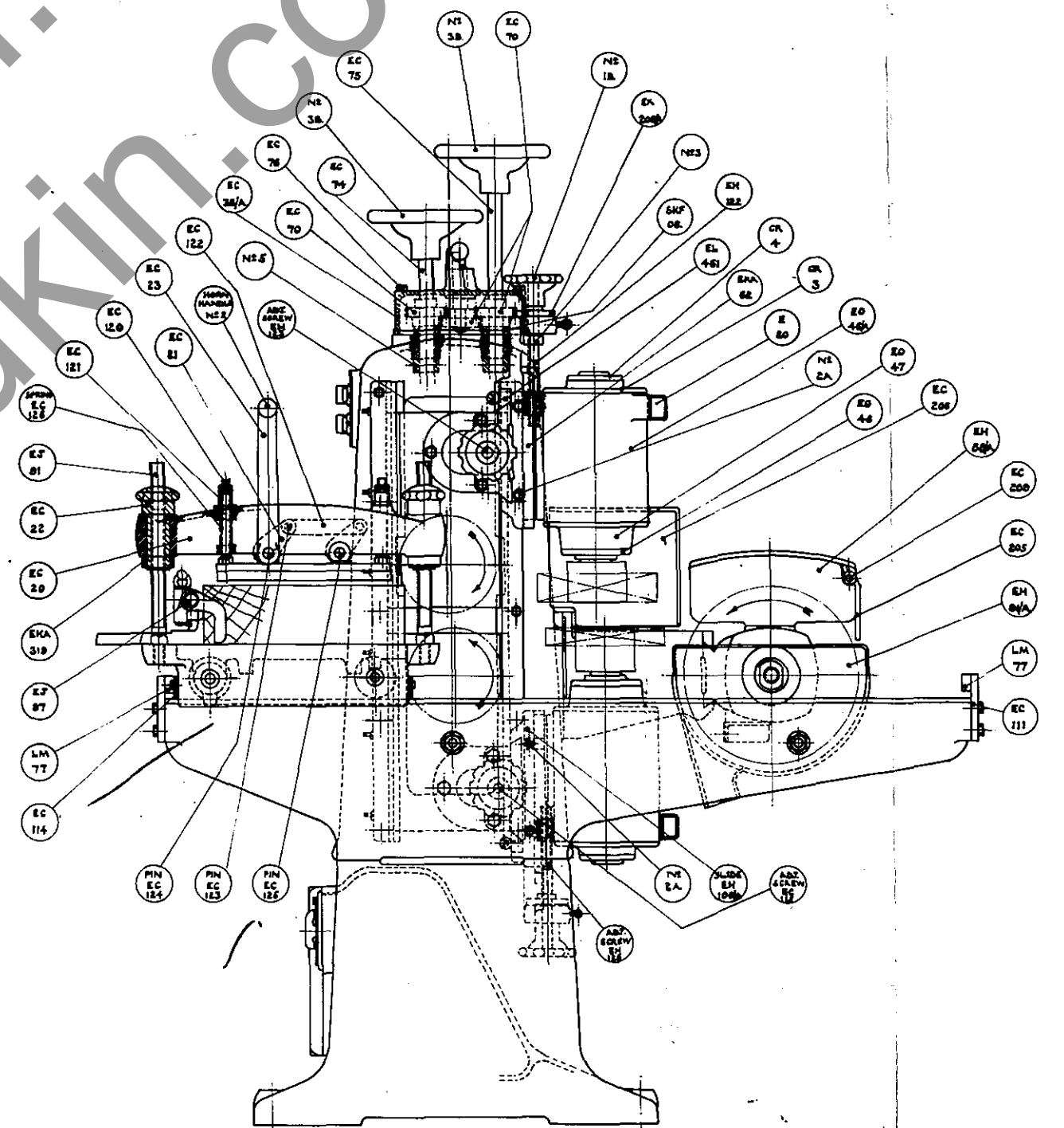
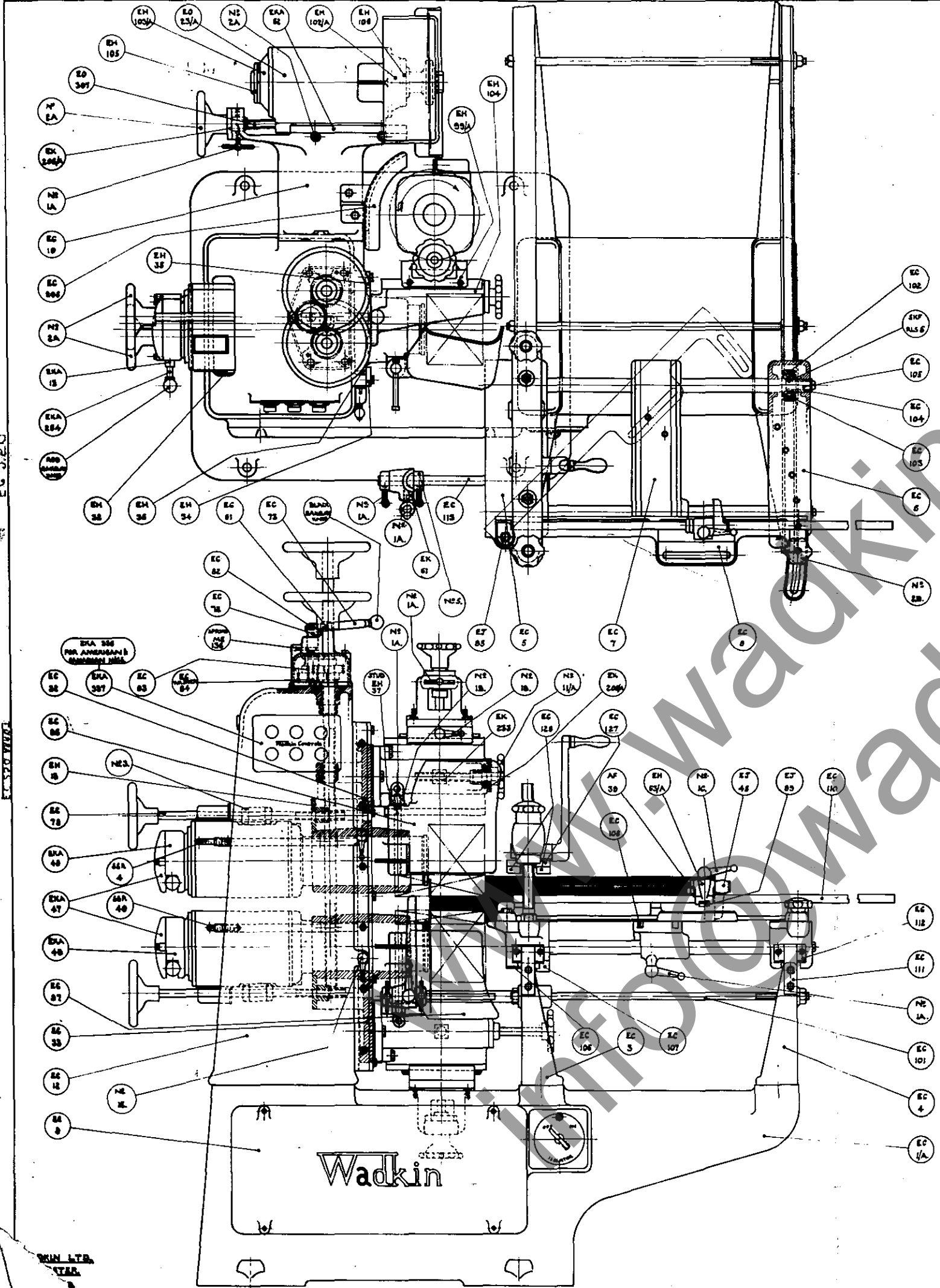

Wadkin Ltd. 1950

Wadkin Ltd. 1950